



Development of a low cost potentiostat using ATXMEGA32

Abdul Muid, Mitra Djamal, and Rahadi Wirawan

Citation: [AIP Conference Proceedings](#) **1589**, 124 (2014); doi: 10.1063/1.4868765

View online: <http://dx.doi.org/10.1063/1.4868765>

View Table of Contents: <http://scitation.aip.org/content/aip/proceeding/aipcp/1589?ver=pdfcov>

Published by the [AIP Publishing](#)

Articles you may be interested in

[RealTime Online Monitoring of Electrocardiogram \(ECG\) using Very Low Cost for Developing Countries](#)
AIP Conf. Proc. **1324**, 251 (2010); 10.1063/1.3526207

[Development of Lowcost Thermophotovoltaic Cells Using Germanium Substrates](#)
AIP Conf. Proc. **890**, 129 (2007); 10.1063/1.2711729

[Development Of Low Cost Germanium Photovoltaic Cells For Application In TPV Using Spin On Diffusants](#)
AIP Conf. Proc. **738**, 337 (2004); 10.1063/1.1841911

[A primer on the use of commercial off-the-shelf software in the development of low cost launch control systems](#)
AIP Conf. Proc. **420**, 875 (1998); 10.1063/1.54890

[Differential Amplifier for Use in a Potentiostat or Voltage Regulator](#)
Rev. Sci. Instrum. **36**, 866 (1965); 10.1063/1.1719740

Development of a Low Cost Potentiostat Using ATXMEGA32

Abdul Muid¹, Mitra Djamal^{2,*}, Rahadi Wirawan^{2,3}

¹*Department of Physics, FMIPA Tanjungpura University, Jl. Ahmad Yani Pontianak, Kalimantan Barat, Indonesia*

²*Department of Physics, Institut Teknologi Bandung, Jl. Ganesha 10, Bandung 40132, Indonesia*

³*Department of Physics, FMIPA Mataram University, Jl. Majapahit 62 Mataram 83125, Indonesia*

* Email: mitra@fi.itb.ac.id

Abstract. Potentiostat is principal devices in modern electrochemical research especially in the investigation of mechanism reaction which associated with the redox chemistry reaction and other chemical phenomena. Several applications measurement is developed based on this tool such as measurement of sample concentrations, quality test of food and medicine, environmental monitoring and biosensors or development of a protein sensor. We have developed a low cost, simple and portable potentiostat with a relatively small dimension. TLC2264 op-amp and ATMEGA32 microcontroller is used to build controller circuit system. Range potential measurement of this tool is between -1600mV and +1600mV within frequency range 1Hz - 1 kHz. The developed instrument has been tested for measuring samples using different voltammetry techniques, like cyclic, square wave, and linear sweep with relative error under 2.5%.

Keywords: potentiostat, microcontroller, control circuit system, op-amp, voltammetry

PACS: 07.07.-a, 82.47.Wx

INTRODUCTION

Potentiostat is principal devices in modern electrochemical research especially in the investigation of mechanism reaction which associated with the redox chemistry reaction and other chemical phenomena. Potentiostat has been made by several establish manufacturers, but the cost to acquire these tools are expensive. On the other side, development of potentiostat for the specific function can simplify the circuit system and reducing the operational cost.

Recently, there has been an increasing interest in developing potentiostat application such as for metal corrosion analysis, environmental monitoring, quality control of food and medicines, biosensor, chemical sensor [1- 6], and protein sensor for the waste dialysate material [7]. Gopinath and Russell (2006) have been successfully developing a low cost portable programmable potentiostat which using 10 bits ADC (analog to digital converter) [8].

In some potentiostat designs that have been performed on other studies, two ADC with a single line (channel) input or a single ADC with two line input is used to measure the current and voltage. Applying the constant voltage setup approach from voltage source devices gives an opportunity just for current measurement. According to this reason, we can use an ADC with a single line (channel) input. The potentiostat circuit design becomes more simple and

able to reduce production costs. Therefore, we are using ATXMega32 microcontroller which includes an internal 12 bits ADC with up to 2MS/s and the internal DAC (digital to analog converter) for the arbitrary waveform generator of 1MS/s. This potentiostat is also supported by a low pass filter circuit.

In this paper, we present the developed potentiostat design which using an ADC single line, methods of calibration measurement and the test results for some technical measurement to an electrochemical cell solution sample.

BASIC CONCEPT OF POTENTIOSTAT

Potentiostat is a device that used to regulate currents and voltages attached to an electrochemical cell. Potentiostat is usually have three electrodes, i.e. the working electrode (WE) is the electrode in an electrochemical system on which the reaction of interest is occurring, reference electrode (RE) is an electrode which has a stable and well-known electrode potential and it is used as a point of reference for the potential control and measurement, and counter electrode (CE) is an electrode which is used to close the current circuit.

The working principle of potentiostat is maintaining the voltage between working electrode and the reference electrode in the certain value by adjusting the current flowing from counter electrode.

In a potentiostat, the controlled variable is the electrochemical cell potential and the electrochemical cell current is the measured variable [9]. So, if the electrochemical cell voltage can be maintained at the certain constant value, the measured current flow between the Working and Counter electrodes can be processed to analyze a sample characteristic based on an I-V curve [10, 11]. Figure 1 shows the scheme of potentiostat circuit.

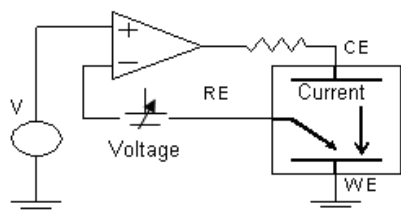

FIGURE 1. The scheme of potentiostat circuit.

POTENTIOSTAT DESIGN

In this work, potentiostat is divided into three main parts: controlling, recording and display. Developed potentiostat design is depicted in Figure 2.

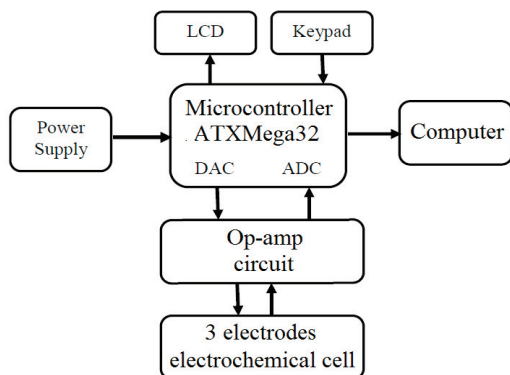

FIGURE 2. Diagram block of developed potentiostat system.

For this design we use ATXMega32 microcontroller which have an internal 12 bits ADC (analog to digital converter) with up to 2MS/s and the internal DAC (digital to analog converter) for the arbitrary waveform generator of 1MS/s. It's more accurate than the design which offered [8].

Analog control circuit of potentiostat utilizes op-amp characteristic that have high input impedance and with a small output current. An analog control circuit for the potentiostat circuit is shown in Figure 3. The main component of this analog control is TLC2264 op-amp that has high input impedance and low noise. In spite of that, low power dissipation of TLC2264 op-

amp is appropriate to be implemented to the sensor. In addition, the low pass filter circuit is applied to the circuit in the order for reducing the harmonic which arises in output signal.

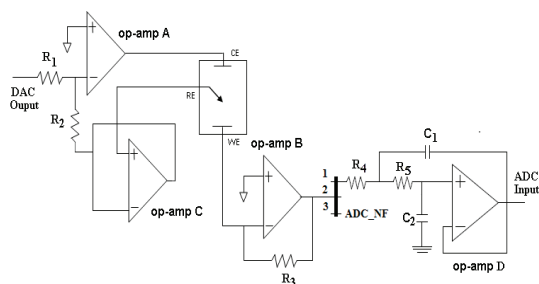

FIGURE 3. Analog control design of a developed potentiostat circuit.

In the schematic design shown in Figure 3, the offset current circuit is not required to shift the current signal from the DAC because the DAC has a built in offset calibration. Therefore, to set the offset current, just need one calibration setup. For digital calibration of DAC current output, zero current value is digitized to 0 and -20.48 mA in 4095. The center of the signal needs to be shifted to zero position because of the center position of digital signals at half of the full scale. The signal amplifying from the DAC to the sample is one, so the applied voltage on the sample has a range of ± 10.24 mV. This value will calibrate on the next step.

Voltage of reference electrode (RE) must be set without need the current flow, meanwhile the current flows from the counter electrode (CE). For the stabilization of op-amp A with an amplification minimum twice, resistor R2 mounted to the inverting input. In the order to prevent the current flows from the RE electrodes, the C op-amp is fitted with an output feedback to the inverting input. In this way, non-inverting circuit amplification working at high frequencies above the signal frequency so that the stability of the op-amp awake. For low frequencies, circuit amplification is one and the impedance of RE electrode same as the input impedance of the op-amp. Therefore, no current flows into the reference electrode.

In the case of frequencies above 1 MHz, the RE impedance becomes smaller and RE will be flowing the currents. This can be fixed by replacing the op-amp with another op-amp that has stable amplification about 1 and FET input. In Figure 3, resistor R3 function is controlling overall of the signal amplification. In the potentiostat design, it is using a variable resistor. Signal amplification is set for making the current in order of microampere can produce a full-

scale signal on the ADC. For the actual values, it's measured in the calibration. This value was chosen because the measured sample has an impedance value in the order of hundreds Ohm. Therefore, 10 mV voltages produce a hundred microampere of current.

In order to data acquisition through a computer, we built the serial communication from the microcontroller to the computer via USB (Universal Serial Bus) connection using an IC FT232RL. The FT232R is a USB to serial UART interface with have advanced features like single chip USB to asynchronous serial data transfer interface, 128 byte receive buffer and 256 byte transmit buffer utilizing buffer smoothing technology to allow for high data throughput, fully integrated AVCC supply filtering - no external filtering required, low operating and USB suspend current [12]. While the voltamogram curve (I-V curve) is made using Netbeans IDE 7.1 for Java application program.

RESULT AND DISCUSSION

The measurement process is controlled by an ATXMega32 microcontroller. The mechanism of the measurement process is presented by the block diagram as shown in Figure 4.

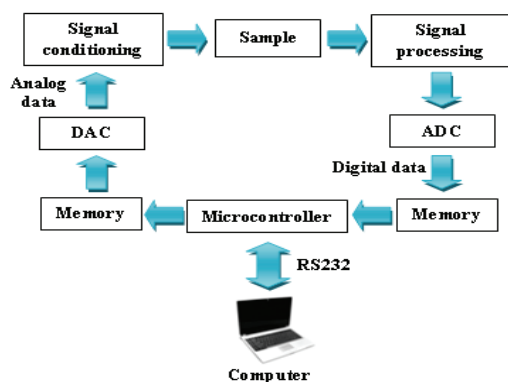

FIGURE 4. The developed potentiostat control system.

Firstly, voltage signal formed by the DAC is applied to the sample by an analog circuit. The measured current output signal is digitized by the ADC and stored in RAM. Using serial communications, this data is sent to a computer for continuous processing. In this way, the working load of the microcontroller is very light and a fast microcontroller or having a big memory capacity not needed.

On the other hand, the selection of op-amps play an important role, because of its effect on the performance of the potentiostat. The system produces a very small current (a few tens microampere). Therefore it requires an op-amp with FET inputs to

ignore the input current bias. In addition, the op-amp should have a gain bandwidth by more than 10 times to the highest frequency used. Due to the lack of bandwidth, there are different amplifying signal of circuit at the highest frequency to the lower frequency. Consequently, low impedance becomes difficult to distinguishable with higher impedance.

Calibration of DAC is a prerequisite work before it's used in potentiostat design. The DAC calibration test results (Figure 5b) showed that there is no significant deviation of measurement voltage value to an ideal value of DAC.

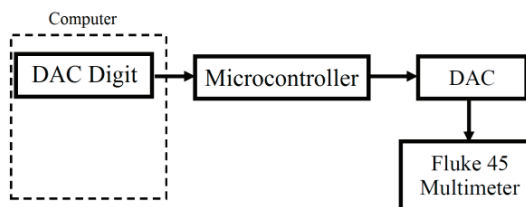

(a)

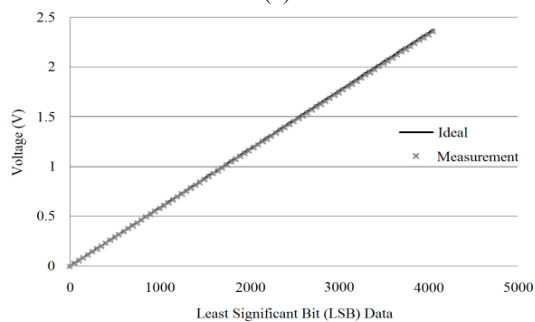

(b)

FIGURE 5. DAC voltage calibration; (a) Schematic DAC voltage calibration measurement, (b) DAC output voltage measurement.

Figure 6 shows the photo of development potentiostat. Potential range measurement of the developed instrument is between -1600mV and +1600mV within the frequency range 1Hz - 1 kHz.



FIGURE 6. Photo of development potentiostat

In order to test the utility of the developed potentiostat, we measure electrochemical cell sample with three different techniques i.e. cyclic voltammetry techniques, square wave voltammetry techniques, and linear swap voltammetry techniques. Figure 7 shows the measurement results of the potentiostat.

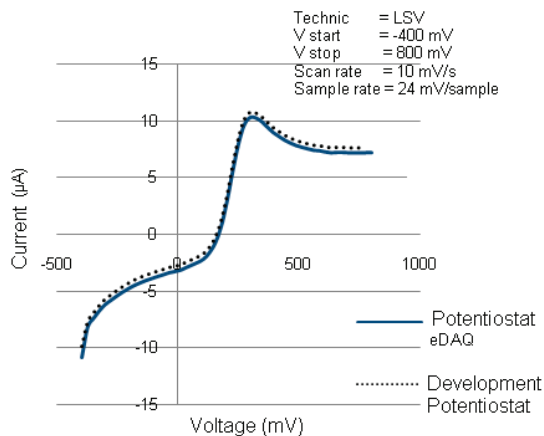
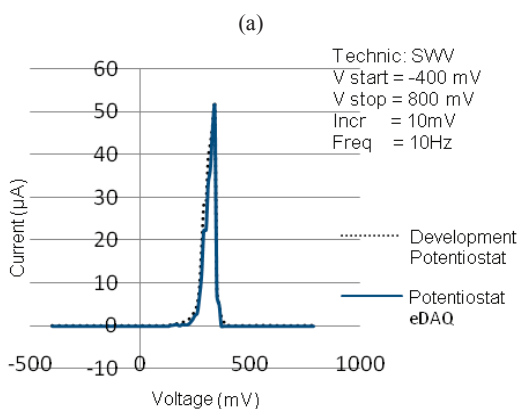
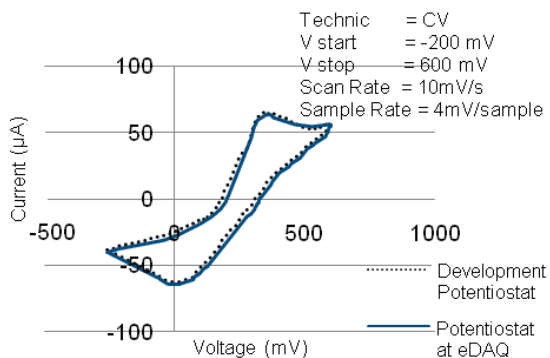
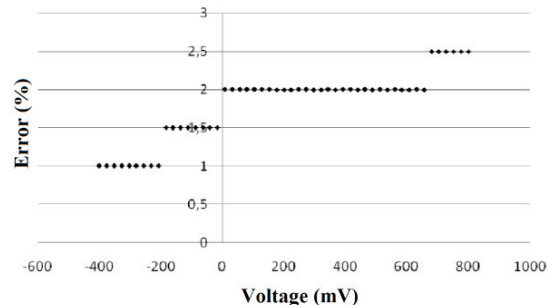
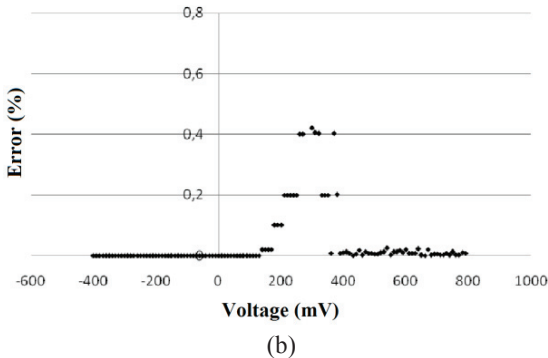
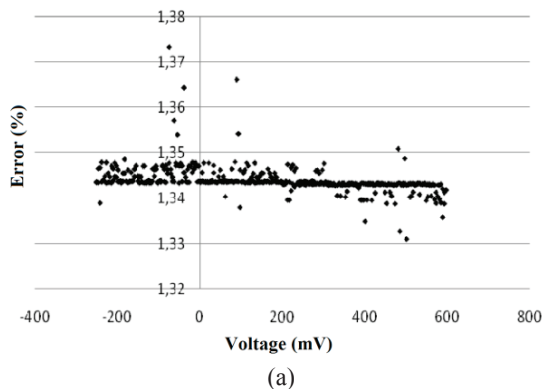

FIGURE 7. Result measurement of some electrochemical cell sample. (a). Cyclic voltammetry techniques; (b) Square

Wave voltammetry techniques; (c) Linear Swap voltammetry techniques.

In the I-V curve from measurement result has the same shape curve between the development potentiostat and from eDAQ potentiostat as standard potentiostat. The current value of measurement result from both potentiostat is similar. Shifting in the conversion process from digital input to the analog input of DAC when it used for high conversion causing the differences result measurement as shown in Figure 6. In this condition, DAC output is shifting from the true value which given to the microcontroller. But, for the low sampling speed we get the small deviation.

Discrepancy of development potentiostat result from standard potentiostat (eDAQ) is depicted in Figure 8.



(c)

FIGURE 8. Error measurement of three different methods (a). Cyclic voltammetry techniques; (b) Square Wave voltammetry techniques; (c) Linear Sweep voltammetry techniques.

Cyclic voltammetry techniques measurement gives an error measurement less than 1.38%, Square Wave voltammetry techniques about 0.5% and Linear Sweep voltammetry techniques is about 2.5%. Based on the error value of measurement results, the square wave voltammetry techniques give a better result than two other techniques. Repeating measurement approach for averaging measured signals effectively reduces the variance.

CONCLUSIONS

A low cost potentiostat uses op-amp and ATXMEGA32 as a controller has been developed. Potential range measurement of this instrument is between -1600mV and +1600mV within the frequency range 1Hz - 1 kHz. The developed instrument has been tested for measuring samples using different voltammetry techniques, like cyclic, square wave, and linear sweep with relative error under 2.5%.

REFERENCES

1. Butarbutar, S., dan Febrianto, Pengujian Mesin EDAQ Untuk Mengukur Laju Korosi, *Sigma Epsilon* 13, 2009, pp. 54-58.
2. C. N. Yarnitzky, "Design and construction of a potentiostat for a chemical metal-walled reactor", *Journal of Electroanalytical Chemistry* 491, 2000, pp. 154-159.
3. Lisdat, F., and Schafer, D., The use of electrochemical impedance spectroscopy for biosensing, *Anal Bional Chem* 391, 2008, pp. 1555-1567.
4. Wei-Song Wang, Wei-Ting Kuo, Hong-Yi Huang and Ching-Hsing Luo, "Wide Dynamic Range CMOS Potentiostat for Amperometric Chemical Sensor", *Sensors, Vol.10*, ISSN 1424-8220, doi:10.3390/s100301782, 2010, pp. 1782-1797.
5. A. Gore, S. Chakrabartty, S. Pal, and E. C. Alocilja, "A Multichannel Femtoampere-Sensitivity Potentiostat Array for Biosensing Applications", *IEEE TRANSACTIONS ON CIRCUITS AND SYSTEMS—I: REGULAR PAPERS*, VOL. 53, NO. 11, NOVEMBER 2006, 2006, pp. 2357-2363.
6. M. H. Nazari, R. Genov, "A Fully Differential CMOS Potentiostat", *IEEE ISCAS 2009 Vol. 1-5*, doi: 10.1109/ISCAS.2009.5118228, 2009, pp. 2177-2180.
7. J. K. Kasi, A. K. Kasi, N. Afzulpurkar, N. Sheikh, "Protein Sensor for the Waste Dialysate Material", 2010 2nd International Conference on Mechanical and Electronics Engineering, 978-1-4244-7481-3 2010 IEEE Vol. 2, pp.307-312.
8. A.V. Gopinath, D. Russell, "An Inexpensive Field-Portable Programmable Potentiostat", *The Chemical Educator* 11, 2005, pp. 23-28.
9. Gamry Instruments, Potentiostat Fundamentals, Application Note, <http://www.gamry.com> (accessed February 2012).
10. Khandpur, R.S., *Handbook of Analytical Instruments*, Tata McGraw-Hill Publishing Company Limited, New Delhi, 1989, pp. 480-484.
11. Agilent Impedance Measurement Handbook (cp.literature.agilent.com/litweb/pdf/5950-3000.pdf).
12. FT232R USB UART IC Datasheet Version 2.10, http://www.ftdichip.com/Support/Documents/DataSheets/ICs/DS_FT232R.pdf (accessed February 2013).