

Building Student's Enterpreneurial Orientation Through Enterpreneurial Intention and Workplace Spirituality

by Abdul Azis

Submission date: 11-Nov-2022 08:33PM (UTC+0700)

Submission ID: 1951115055

File name: Heliyon_Oktober_2022.pdf (1.16M)

Word count: 7593

Character count: 43503



Research article

Building students' entrepreneurial orientation through entrepreneurial intention and workplace spirituality



Abdul Azis Bagis*

Faculty of Economics and Business, Mataram University, West Nusa Tenggara Province, Indonesia

ARTICLE INFO

Keywords:

Entrepreneurial intention
 Entrepreneurial orientation
 Workplace spirituality
 University environment

ABSTRACT

This article aims to determine the effects of entrepreneurial intention on students' entrepreneurial orientation and examine the moderation of workplace spirituality. This study uses a quantitative approach by distributing questionnaires to the five largest state universities in Eastern Indonesia, involving 397 students in entrepreneurship programs. The study results reveal that a spiritual workplace can counterproductively moderate the intention to build students' entrepreneurial orientation. In the context of Indonesian students, it seems that subjective norms have the most decisive influence on intentions. Several suggestions were offered regarding the meaning of the university environment as students' habitat for learning and the importance of integrating spirituality in the context of academic work to become a true entrepreneur. This study highlights that entrepreneurial orientation can be built with strong intentions even though workplace spirituality does not fully support work-based entrepreneurial learning.

1. Introduction

Facing the current decade of disruption era, students and university administrators to adjust according to the challenges they are experiencing. Disruption challenges often impact changing the benefits of knowledge and skills learned, leading to the expiration (Christensen et al., 2003). Thus, there is a gap between what is known and mastered by students with what is needed in the practical world. This condition is also experienced by students of business management education who aim to become successful business entrepreneurs. The gap between knowledge, skills, and needs in the business world tends to widen from year to year, and the need for alignment of the undergraduate curriculum with the regional world of work (Kleckner and Butz, 2020). Many mismatches exist between the workforce's skills and the labour market's needs (González Canché, 2018). There is a critical link between education, business creation, and performance (Raposo and Paço, 2011). The challenge of higher education in Asia, which is oriented towards increasing efficiency, is more revenue-stimulating than innovation (Cheng and Adejumo, 2021). For this reason, the students themselves need faster and more effective adjustments on an ongoing basis. A mindset and self-efficacy are required to enable prospective entrepreneurs to face change challenges more effectively (Godwin et al., 2016). The role of

attitude and self-efficacy is helpful as a mediation of entrepreneurship education in building the mindset of students (Wishnu et al., 2020).

Business schools teach students that "greed is good" by focusing not on improving society but on shareholder benefits and overemphasising the importance of maximising profits (Mangan, 2006, as cited in Friedman and Friedman, 2014). Leaders in higher education need to follow the development of the situation to produce graduates who are by the qualities required by the industry (Siddoo et al., 2019). Ideally, modern education is developed based on humanism and enlightenment thinking for adaptation and continuous development (Müller, 2021). Now is the time for business education management to take advantage of spiritual values, which makes entrepreneurship more meaningful. It is realised that there has been no research on entrepreneurial intentions and orientation that reveals the work spirituality of business students that comes from spiritual strength (Baehr, 2017). This research is a new study that examines the influence of attitudes and contextual environment on productive behaviour. In addition, this research is intended to close the research gap related to the academic climate that supports students' spiritual intelligence. Business students can be seen as people who choose entrepreneurship as a future career, respected and supported by the academic community.

The results of research (Oliveira and Rua, 2018; Vamvaka et al., 2020; Abdullah and Saeed, 2019) confirm that students' intentions significantly

* Corresponding author.

E-mail address: azis.bagis@unram.ac.id.<https://doi.org/10.1016/j.heliyon.2022.e11310>

Received 8 May 2022; Received in revised form 29 July 2022; Accepted 24 October 2022

2405-8440/© 2022 The Author(s). Published by Elsevier Ltd. This is an open access article under the CC BY-NC-ND license (<http://creativecommons.org/licenses/by-nc-nd/4.0/>).

impact their behaviour. Another view is that intention does not fully influence orientation directly (Paço and Ferreira, 2013; Anwar et al., 2021). Business lessons are becoming more precise, with many students seeking extracurricular practices and taking additional classes to learn how to win business (Hitka et al., 2021). The critical role of the academy in introducing spirituality has returned to its rightful place and is exerting considerable influence inside and outside the university walls (Salcedo and B Lazatin, 2021). Higher education institutions help students build better relationships after college and prepare for long-term success. Educational institutions, including entrepreneurship training in universities, need the support of all parties, especially the government (Salisu, 2020). The entrepreneurship education experience in Indonesia requires a mindset to determine students' intentions to become entrepreneurs and support a conducive environment (Handayati et al., 2020). Applying the concept of organisational climate to higher education institutions and examining the factors contributing to students' perceptions of the university's entrepreneurial climate (Bergmann et al., 2018). In teaching effectiveness, workplace spirituality concerns inner life, meaningful work, and a sense of community (Mat et al., 2012). Workplace spirituality in higher education benefits academic performance, organisational performance, and institutional loyalty (Geaquinto et al., 2020).

However, this research answers the challenges of business students in the era of disruption to be creative, innovative and dare to face measurable risks by demonstrating their business attitudes and behaviour. For this reason, a meaningful academic atmosphere is needed as an organisational spirituality that reflects noble values to accelerate student orientation.

2. Theoretical foundation and hypotheses development

Business management education institutions should be able to give birth to true business entrepreneurs with new and different business ideas, meet market expectations and take into account the business risks that will be faced (Lackeus, 2015). The ability of students who are proactive, innovative, and dare to take risks is known as a measurable orientation behaviour across national and cultural boundaries to create value within organisations (Covin and Miller, 2014), and measurement of orientation can be carried out on student populations from different academic programs (Taatala and Down, 2016). Through proactiveness, creative ideas can be generated that need to be expressed and linked to market needs to discover the possibility of consumer acceptance and appreciation of these ideas into innovative works. Self-perceived creativity becomes the beginning of the entrepreneurial process because it can influence the ability to design a new product and serve (Abdelfattah et al., 2022). The need for a review of individuals with higher levels of orientation and propensity to apply new technological methods (Rubin and Callaghan, 2019). Products with creative and innovative power must be decided by measuring various business risks. The study of orientation can be applied to higher education institutions (De, 2021). All these abilities need to be possessed by business students with support from related parties, especially the academic community from the university's internal environment (Rania et al., 2014). In line with the planned behaviour theory that people's behaviour is a function of their attitudes and environment, the student's intention can be interpreted as a strong desire to become a business entrepreneur. Students' strong passion or determination needs to be built from the students themselves, as well as an effort to adapt to the challenges of recent disruption. Meanwhile, the intention-action gap among student entrepreneurs is also related to contextual factors, including family background, age, gender, and characteristics of the university environment (Shirokova et al., 2015). Behavioural intention is the function of attitude towards behaviour, subjective norms, and perceived behavioural control (Ajzen, 1991). At the same time, behavioural intention is one's likelihood of performing the

behaviour. It turns out that attitudes and culture have succeeded in influencing students' intentions to become entrepreneurs (Wardana et al., 2021), and the three determinants of intentions are described respectively as the degree to which a person has a favourable or unfavourable appraisal of behaviour (Vamvaka et al., 2020; Abdullah and Saeed, 2019).

The theory of planned behaviour effectively predicts specific intentions and behaviours, such as regular exercise among adolescents (Lu et al., 2022) and demographic and behavioural factors (Wahidmumi et al., 2020). It is widely implemented in student entrepreneurship studies. The fundamental starting point for Stern's approach (based on Lewin's field theory) is the understanding that behaviour is a function of the organism and its environment, or in the language of psychology known as ABC, behaviour (B) is 'the interactive product of personal environmental attitude variables (A) and contextual factors (C)' (Stern, 2000). Student attitude factors towards entrepreneurship play an essential role in mediating entrepreneurship education and self-efficacy toward student mindsets (Wishnu et al., 2020). Student self-efficacy is a form of behavioural control towards entrepreneurial intentions. Subjective norms, which make fathers role models, strongly influence students' tendency to become entrepreneurs, especially girls (Plopeanu et al., 2018). Therefore, the hypothesis is provided as follows:

- H1. Attitude towards entrepreneur behaviour positively correlates with students' entrepreneurial intention.
- H2. Subjective norm is positively associated with the entrepreneurial intention of students.
- H3. Perceived behavioural control is positively associated with students' entrepreneurial intention.

The strength of determination in this study is the entrepreneurial intention of students, ready to be raised and utilised for productive activities and beneficial for the welfare of developing countries. Thus connecting entrepreneurship and facilitated by spiritual development is becoming more relevant and will be interesting all the time, and more research can be done (Phan et al., 2021) and the importance of alignment between the individuals in the organisation and the organisation's values (Kleijnen et al., 2009). Based on the views of psychologists, the entrepreneurial intention is the ability of students to improve themselves through study and practice until they reach the limit of their ability to develop talents and skills. It is proven that intention can be mediated by students' self-confidence (Liu et al., 2019). The theory of planned behaviour belongs to related theories that employ a cognitive approach to explain behaviour that focuses on individual attitudes and beliefs. Not only is it one of the most cited theories, but it is also one of the most widely applied behavioural theories. This suggests that intention to action is the best predictor of behaviour. Intention itself is the result of a combination of attitudes towards action. That is, positive or negative appraisals of actions and their expected outcomes and subjective norms reflect what others think they should do and their tendencies to meet those expectations (Al-mamary et al., 2020). This entrepreneurial intention reflects the will realised within the students (*inside out*). The study of the intentions of university students becomes richer with an acceleration of the mindset in addition to the contribution of culture and education (Mukhtar et al., 2021). Students' intentions can build productive behaviour that reflects an orientation by showing students' proactiveness, innovativeness, and risk-taking (Bolton and Lane, 2012). Entrepreneurial action as behaviour is generally driven by intentions, although not every intention eventually turns into actual action (Bogatyreva et al., 2019). Even though the role of entrepreneurial intention can build student entrepreneurial orientation, it still requires the support of a conducive academic environment. It has been proven that the educational environment can fundamentally impact students' decisions to start a new venture or vice versa, that they

will abandon their intentions (Id and Vallanti, 2022). Although many studies have proven that IO can build EO, on the other hand, there is the feedback that shows empirical results of the relationship and positive influence of the orientation dimension of students on intentions (Kumar et al., 2019). The positive impact of organisational innovation on organisational effectiveness is more significant among individuals who choose improvements rapidly (Naveed et al., 2022). The innovation process can be carried out more efficiently and effectively through digital tools (Marion and Fixson, 2021). Although there are normative-regulatory, sociocultural, and economic-financial barriers faced by entrepreneurs, in the end, it must be recognised that there is a medium/long-term temporal relationship between intentions and actions (Oliveira and Rua, 2018). The uncertainty factor plays a vital role in the success of the innovation and new product development (NPD) process (Marzi, 2022). However, academic studies are still needed to ascertain the essential role intentions play in the decision-making process for starting a new business venture (Cho and Lee, 2018). Thus, the hypothesis is provided as follows:

H4. The entrepreneurial intention is positively associated with the entrepreneurial orientation of university students.

The concept of climate has received much attention, and universities have implemented measures to improve their climate to encourage the tendencies of students and researchers (Bergmann et al., 2018).

It is realised that the unique concept of spirituality has not yet been agreed upon. Therefore its dimensions and characteristics depend on the approach used. Spirituality can also be considered religious (Geaquinto et al., 2020). The work environment can also be understood as values shaping attitudes, behaviour, and performance. Among these values, trust is accepted as an organisational environment rich in spirituality. Trust is proven to mediate workplace spirituality in building job performance (Bienstock and Daniel, 2019). In the context of the SMEs business climate, informational trust is considered a type of user confidence that can be a moderating variable of the influence of social media on innovation (Al Halbusi et al., 2021), and trust plays an intervention role on customer satisfaction (Uzir et al., 2021). Trust and user experience affect user satisfaction and can mediate stimulants on user satisfaction (Hossain et al., 2020). Trust in government institutions and others proved essential for self-efficacy (Hassan et al., 2022). Cooperation between universities and the business world can encourage co-creation among students. The impact of the value of co-creation on satisfaction can influence behaviour (Al Halbusi et al., 2020). We are interested in how students perceive their university in the Indonesian context and the extent to which the university's steps in encouraging entrepreneurial and spiritual perspectives are well suited to our research objectives. The empirical findings show that workplace spirituality positively and significantly impacts lecturer involvement, commitment, workforce agility, trust, and empowerment (Soliman et al., 2021). Much academic discussion about workplace spirituality to assess spirituality as a positive factor in the higher education system is increasing (Brucaj and Karci, 2013), and maximising the emergence of intention requires the support of a conducive environment. The challenge for related parties in higher education today and in the future is to build an academic climate (Rania et al., 2014) that can raise enthusiasm and encourage the emergence of intellectual, social, and ethical potential for all students.

Academic climate can be defined as psychosocial conditions experienced by students in a higher education environment (Bergmann et al., 2018). They can function as a strengthening of the internal environment to actualise intention in building a more optimal student orientation (Taatila and Down, 2016). The importance of workplace spirituality as an element in developing an inclusive organisational culture is increasingly attractive (Porter and Mitchell, 2016), and the study of university characteristics and resources examines how the context of a university impacts students' processes (Rasmussen and Borch, 2010). Understanding the diversity of traditions, religions, and spiritual beliefs represented by community members, universities show that spirituality plays a vital role

in the student's educational experience (Williams and Allen, 2014). Researchers discuss the recent emergence of spirituality on campus, report on the potential benefits and challenges of addressing spirituality in higher education, and report that spirituality is becoming more common on campuses in the United States (Waggoner, 2016). Strategies to increase workplace meaningfulness in the higher education system by focusing on the spiritual needs and spiritual growth of university students and staff (Soliman et al., 2021). University characteristics strongly influence climate perceptions (Rasmussen and Borch, 2010). Understanding the diversity of traditions, religions, and spiritual beliefs represented by community members shows that spirituality plays a vital role in students' educational experiences (Brucaj and Karci, 2013). The academic climate and university support are defined as a workplace spirituality that can excite students, and the campus is a working habitat to prepare for an entrepreneurial career. This study considers workplace spirituality to play an intervention role in achieving EO for students who have EI to become business entrepreneurs. Therefore, this study proposes the final hypothesis as follows:

H5. Workplace spirituality will moderate the relationship between entrepreneurial intention and student entrepreneurial orientation.

3. Research methods

3.1. Research design and data collection

This study uses a quantitative approach to understand how entrepreneurial intentions, and workplace spirituality, explain students' entrepreneurial orientation. This research was conducted in Eastern Indonesia by considering cultural diversity and the richness of local wisdom values. Five major state universities have been selected that have economics and business programs. To maintain privacy and research ethics, respondents were allowed to choose anonymity. The Mataram University Institutional Research Committee has approved the rules of research ethics. This research focuses on developing student entrepreneurship orientation with the unit analysis of university business students. At the same time, the unit of observation is individual students who have received entrepreneurship courses in their respective study programs. The data is taken from a sample of students taking entrepreneurship courses at state universities, having a curriculum regulated by APSMBI (Alliance of Indonesian Business Management Study Programs), so there are relatively many similarities. The students were chosen randomly from the student population using convenience sampling,

Table 1. Demographics of the respondents.

No	Characteristic	Frequency	Percentage
1	Gender		
	Female	243	61.23
	Male	154	38.77
2	Year Class		
	2015	19	4.66
	2016	24	6.11
	2017	121	30.47
	2018	233	58.76
3	Parents Occupation		
	Business Entrepreneur	146	36.89
	Farmer	164	41.33
	Civil Servants	49	12.27
	Teacher/Lecturer	29	7.19
	Soldier	9	2.32
4	Subject		
	Management	145	37.52
	Accounting	129	32.49
	Economics	123	30.98

Table 2. Rule of thumbs partial least square test.

Test	Parameter	Rule of thumbs
Convergent validity	AVE	>0.5
	Outer loading	>0.7
Discriminant validity	The squared root of AVE and correlation among latent variables	The squared root of AVE must be greater than all correlations among latent variables
Reliability	Cronbach's alpha	0.6
	Composite reliability	0.7
Hypothesis test	t-Statistic	>1.96: hypothesis proven

Note: Average Variance Extracted (AVE). Source: (Ringle and Sarstedt, 2021).

widely used in entrepreneurship studies. The questionnaires were distributed to 500 students using the google forms platform via email and WhatsApp. A total of 397 students responded, with 79 percent of return. Based on the demographics of the respondents in Table 1 informs the details of the demographic respondents in this survey. The questionnaire asked general questions about their characteristics, study period, and entrepreneurial activity. The survey shows that the number of students for the 2015 and 2018 academic years is higher. Family backgrounds generally come from small entrepreneurs, mostly farmers and employees. Demographic variables should not affect intentions directly but can be very useful in identifying their influence on perceived control, attitudes, and subjective norms. As depicted in Figure 1, the relationship between variables in this study was performed from previous studies' empirical evidence and literature.

3.2. Measurement and data analysis

The author uses a questionnaire, EO, IE, and Workplace Spirituality with slight adjustments for the context of students. The intention has been measured through a 5-point Likert-type scale with five items to evaluate the extent to which study participants have the intention to start a business in the future, a scale for capturing EI constructs (Brown et al., 2006) and measuring workplace spirituality in an Asian context (Petchsawang and Duchon, 2009). As for the orientation of students to capture the EO construct (Taatila and Down, 2012).

4. Results and discussion

4.1. Result of outer model test

The outer model test consisted of validity (both convergent validity and discriminant validity) and reliability. Convergent validity is an

agreement between measures of the same construct assessed by different methods (Guo et al., 2008). The assessment of the results of the convergent validity test is carried out in two stages, the first stage is to test the overall construct validity based on the AVE and communality values, and the second stage is to test the validity of the formative indicators based on the outer loading value. If the AVE and communality values are >0.5, then the construct is declared to have met the requirements of convergent validity, meaning that all indicators are valid. Table 3 explains that, as a rule of thumb, and average variance extracted of at least 0.50 is highly recommended.

All latent variables have AVE and communality values of more than 0.5, so the latent construct/variable is declared to meet the requirements of convergent validity. Outer loading values, all indicators are declared valid with a value of more than 0.7 (Garson, 2016), as shown in Table 4.

The assessment of the results of the discriminant validity test was carried out in two stages, namely, the first stage testing the overall construct validity based on comparing the AVE root value of a latent variable with the correlation value between latent variables, and the second stage testing the validity of indicators based on the cross-loading

Table 3. AVE and communality of latent variables.

Latent Variables	AVE	Communality	Criteria
Workplace Spirituality	0.538	0.538	Qualified
Attitude Toward Behaviour	0.546	0.546	Qualified
Entrepreneurial Orientation	0.564	0.564	Qualified
Entrepreneurial Intention	0.536	0.536	Qualified
Perceived Behavior Control	0.540	0.540	Qualified
Subjective Norm	0.583	0.583	Qualified

Note: Average Variance Extracted (AVE).

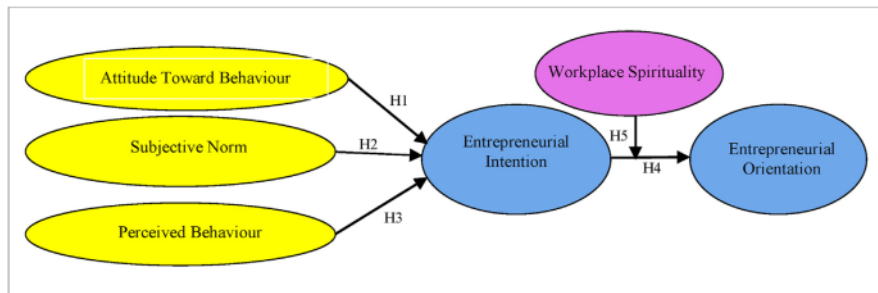

Figure 1. The research framework. Source: own elaboration based on Shir-okova et al. (2015), Lu et al. (2022), Mukhtar et al. (2021), Handayati et al. (2020). Data analysis was carried out using the SEM-PLS (structural equation model partial least square) method, a variance-based SEM type. The outer model test includes convergent validity, discriminant validity, and reliability tests. The PLS estimation method uses the algorithm method and the bootstrap method. The algorithm method on SmartPLS results in the outer loading value, the cross-loading of each indicator, the AVE value, composite reliability, Cronbach's alpha, path coefficient, and R². The bootstrap method results in path coefficient and t-statistic. Table 2 explains the rule of thumbs partial least square test.

Table 4. Outer loading of latent variables.

Latent variables	Indicators	Outer loading	Criteria
Workplace spirituality	WS1	0.733	Valid
	WS2	0.703	Valid
	WS3	0.744	Valid
	WS4	0.751	Valid
	WS5	0.734	Valid
Enterpreneurial orientation	EO1	0.742	Valid
	EO2	0.787	Valid
	EO3	0.721	Valid
Attitude toward behaviour	ATB1	0.741	Valid
	ATB2	0.753	Valid
	ATB3	0.725	Valid
	ATB4	0.755	Valid
	ATB5	0.722	Valid
Subjective norm	SN1	0.735	Valid
	SN2	0.795	Valid
	SN3	0.801	Valid
	SN4	0.744	Valid
	SN5	0.741	Valid
Perceived behavior control	PBC1	0.728	Valid
	PBC2	0.733	Valid
	PBC3	0.737	Valid
	PBC4	0.731	Valid
	PBC5	0.743	Valid
Enterpreneurial intention	EI1	0.720	Valid
	EI2	0.720	Valid
	EI3	0.736	Valid
	EI4	0.752	Valid
	EI5	0.731	Valid

Table 5. The squared root of AVE of Latent Variables.

Latent variables	AVE	The squared root of AVE
Workplace spirituality (WS)	0.538	0.733
Attitude toward behaviour (ATB)	0.546	0.739
Enterpreneur orientation (EO)	0.564	0.751
Enterpreneurial intention (EI)	0.536	0.732
Perceived behavior control (PBC)	0.540	0.735
Subjective norm (SN)	0.583	0.764

Table 6. Correlation of latent variables matrix.

	WS	ATB	EO	EI	PBC
Attitude toward behaviour (ATB)	0.207				
Enterpreneur orientation (EO)	0.483	0.366			
Enterpreneurial intention (EI)	0.294	0.350	0.460		
Perceived behavior control (PBC)	0.256	0.250	0.387	0.415	
Subjective norm (SN)	0.265	0.251	0.327	0.472	0.251

value. Suppose the AVE root value is greater than the correlation value between latent variables (latent variable correlation). In that case, the construct is declared to have met the discriminant validity requirements, meaning that all indicators are valid. On the other hand, if the AVE root value is less than the correlation value between latent variables, the construct is declared to have not met the discriminant validity

Table 7. Composite reliability and cronbachs alpha.

Latent variables	Composite reliability	Cronbach's alpha
Academic climate	0.853	0.787
Attitude toward behavior	0.858	0.793
Entrepreneur orientation	0.794	0.612
Entrepreneurial intention	0.852	0.783
Perceived behavior control	0.854	0.787
Subjective norm	0.875	0.822

requirements, meaning that there are still invalid indicators, as shown in Table 5. Table 6 shows that the square root value of AVE for each construct is greater than the correlation value, so the construct in this research model can still be said to have good discriminant validity (Ringle and Sarstedt, 2021).

Test the reliability of latent variables as measured by composite reliability and Cronbach's alpha from a set of indicators for each latent variable. The set of indicators for latent variables is declared reliable if Cronbach's Alpha >0.6 and the Composite Reliability value is >0.7 (Ringle and Sarstedt, 2021). A common method bias becomes apparent when there are inherently significant correlations (r > 0.9) between the main components (Phillips, 2013), as shown in Table 7. All latent variables were declared reliable, where all latent variables have a composite reliability value of more than 0.7 and Cronbach's alpha of more than 0.6.

4.2. Result of inner model test

Figure 2 shows the coefficient path or weight of the influence of each exogenous latent variable on the endogenous latent variable. The path coefficients of ATB (attitude toward a behaviour), SN (subjective norm), and PBC (perceived behavioural control) on EI (entrepreneurial intention) were 0.191, 0.355, and 0.278, respectively. The fit test is assessed based on R2, Q2, and F2 values. Based on the model obtained, two R2 values of 0.350 and 0.373. The value of the first R2 indicated that the predictive power of the EI model using the variables ATB, SN, and PBC was categorised as moderate, and the second R2 value indicated that the predictive power of the EB model based on the AC variable and the EI* AC interaction variable is also categorised as moderate. Q2 (1 - {1 - R1^2}{1 - R2^2}) is a measure of whether the model has predictive relevance or not. The Q2 obtained is 0.592, which explains that the model in this study has a predictive relevance value, where the model used can present the information contained in the research data by 59.2%. The effect size indicated by the value of F2 indicates the relative predictive power of an exogenous variable in predicting the model if the variable is excluded from the model. Calculation of effect size using the following formulation:

$$F^2 = \frac{R^2_{overall} - R^2_{exclude}}{R^2_{overall}}$$

Based on this formula, the effect of each exogenous latent variable on the endogenous latent variable is obtained, as presented in the following Table 8.

The effect size attitude toward behaviour towards entrepreneurial intention is categorised as weak. Meanwhile, subjective norms and perceived behavioural control are classified as moderate effect sizes. Hypothesis testing with t-test through bootstrap resampling method to produce t-statistics value. The t-test was conducted to test the significant path coefficient of the exogenous latent variable on the endogenous latent variable individually or to test the effect of the latent exogenous variable on the endogenous latent variable (Howard, 2013). If the t-stat < 1.96, it is rejected, and if the t-stat > 1.96, then the hypothesis is accepted. Structural equation modelling calculations are shown in

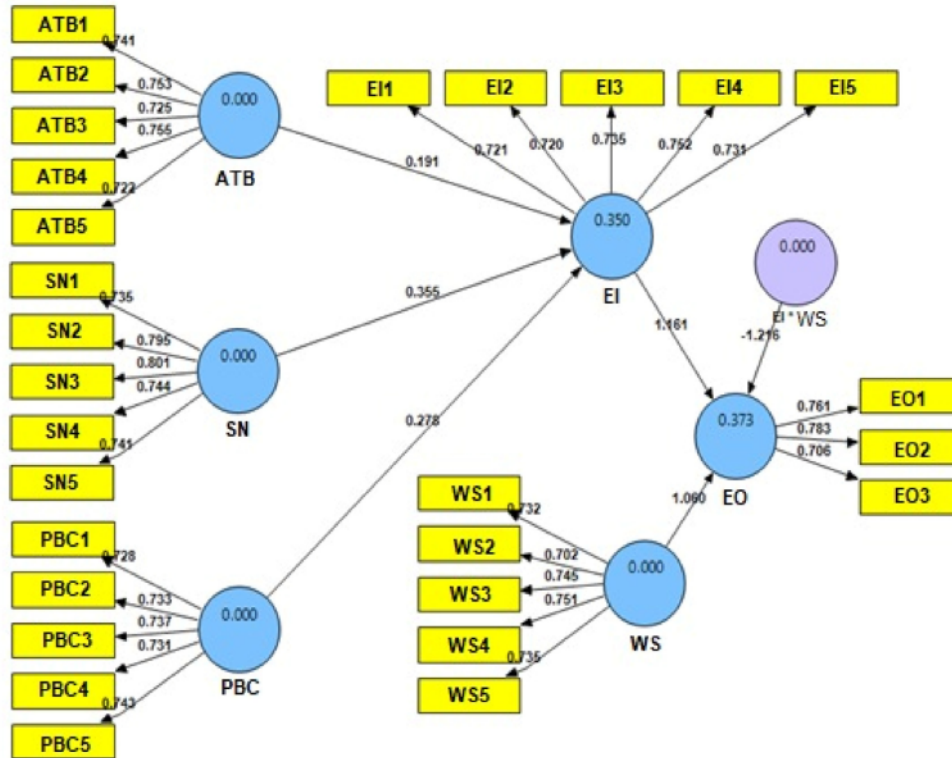

Figure 2. Output algorithm SmartPLS (ATB, SN, PBC, EO, EI, WS).

Table 8. Effect size of exogenous latent variables.

Overall R ²	Exclude variables	R ² exclude	F ²	Category
0.350	ATB	0.318	0.091	Weak
	SN	0.238	0.320	Moderate
	PBC	0.280	0.200	Moderate

Note: ATB = attitude toward behaviour; SN = subjective norm; PBC = perceived behavior control.

Figure 3, explains the calculated t value between indicators with variables and variables with variables.

ATB (attitude towards behaviour), SN (subjective norm), and PBC (perception of behavioural control) have a significant effect on intentions (results in Table 9). In the context of Indonesian students, it is seen that subjective norms have the most decisive influence. This is in line with the culture and vision of the academic community in business studies. In the subjective norm variable (SN), it is known that respondents' perceptions of approval or support from their social environment for their career choice to become an entrepreneur are relatively high, especially support from close family. Subjective norm is the extent to which students regard starting a business as the norm among people who is important to them. Subjective norm combine perceived social pressure to perform or not engage in entrepreneurial behaviour. This finding is in line with the

communal culture that is widely characterised by Indonesian society (Butar Butar, 2018). Family economic education that encourages students' economic literacy affects entrepreneurial intentions (Suratno et al., 2021).

The students' entrepreneurial intention was proved to affect entrepreneurial orientation significantly. In the context of eastern Indonesian students, workplace spirituality shows a counter-productive role in moderating the effect of entrepreneurial intentions on entrepreneurial orientation. Students have not fully understood the context of broad questions such as spiritual diversity in an academic climate. The internal environment of higher education is perceived as a place of learning and not yet natural as a place to work and gain meaningful business experiences. Consistent with these findings, most multi-national employees in the UK who are ethnically diverse think spirituality is not something of interest and feel comfortable practising in the workplace (Foster and Foster, 2019). Workplace spirituality is a stark reality in today's business environment and should not be ignored. Scientists have found no more reductive explanation for the phenomenon in that the concept lacks even a commonly accepted definition (Hassan et al., 2016). Therefore educators need to incorporate in their teaching the importance of Eastern philosophical and religious beliefs to facilitate a deep and meaningful appreciation and understanding of the subject and to emphasise its uniqueness (Phan et al., 2021); thus, workplace spirituality can be felt more by entrepreneurial students.

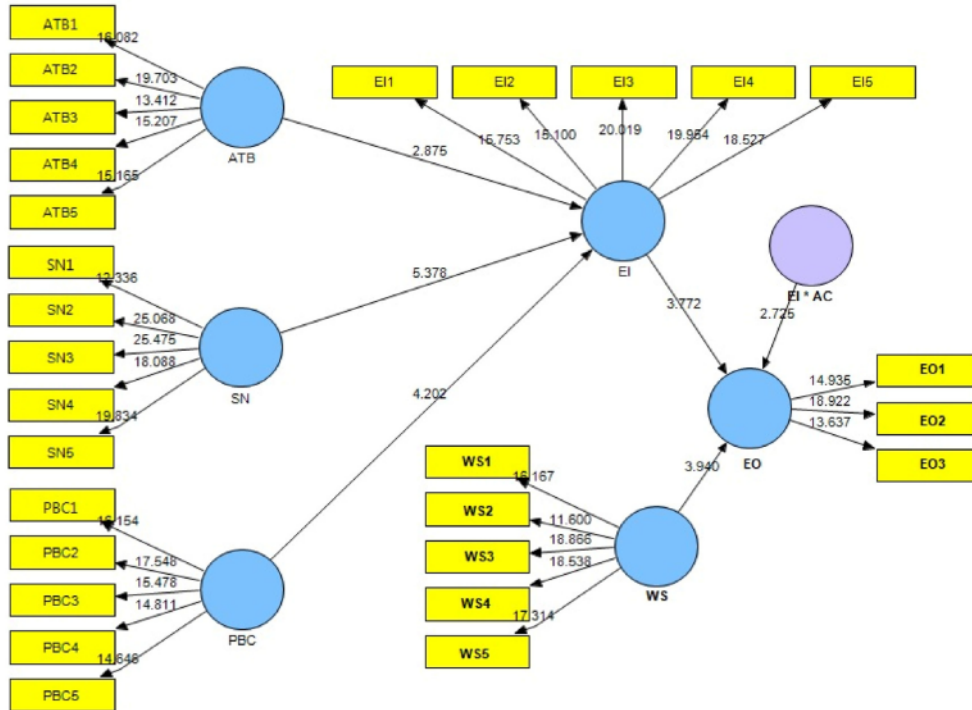

Figure 3. The Bootstrapping resampling method of smartPLS (EO, WS, EI, ATB, SN, PBC).

Table 9. Summary of hypothesis test results.

Hypothesis	Consequence	t _{stat}	Decision
H1	ATB → EI	2,875	Accepted
H2	SN → EI	5,378	Accepted
H3	PBC → EI	4,202	Accepted
H4	EI → EO	3,772	Accepted
H5	EI*WS → EO	2,725	Accepted

5. Conclusion

Building a student's entrepreneurial orientation that is proactive, innovative, and willing to take risks requires a strong entrepreneurial intention, which is supported by a positive attitude to being an entrepreneur, close family support for students, and control behaviour accompanied by students' self-efficacy. This study shows that a workplace spirituality that students do not internalise can inhibit the influence of entrepreneurial intention on students' entrepreneurial orientation. The role of workplace spirituality in generating creative energy makes entrepreneurship a proud professional career choice. The results show that most business students consider spirituality not to be something they feel comfortable discussing in the study room or practising in the workplace and that there are no clear policies or procedures to support management or students.

5.1. Limitations/implications

The author acknowledges that this is a relatively new topic in Indonesia. We do not claim that our findings can be generalised to all workplaces. Nonetheless, this pilot study raises several questions that

cannot be answered by the results presented here. It is recommended to increase the conduciveness of the academic environment as a workplace spirituality that provides high readiness for students to face the challenges of today's disruption. Thus, it is time to make the environment of a business education institution not only a place of learning but also a place of creativity and innovation, with a more meaningful academic atmosphere. It is realised that this research was conducted in several economic and business education institutions at state universities in eastern Indonesia, so it does not fully represent the internal conditions of universities with diverse values, cultures, and beliefs.

Further research is needed, both quantitative and qualitative, about workplace spirituality in universities. Furthermore, the questionnaire uses a convenience sampling technique rather than a random sampling of the entire population. The responses obtained may not represent all economics and business students fully. The college manager creates the availability of a spiritual dimension in the workplace related to the meaning of learning and working on starting a career as an honest and responsible entrepreneur. Building mutual trust is the principal capital for business in this disruption era. Increasing the critical role of spirituality in students' academic and personal development, who are guided by spiritual values and a strong desire to live a balanced and healthy work life. University management must formulate strategies to develop students' spiritual needs and create an academic context.

Declarations

Author contribution statement

Abdul Azis Bagis, Doctoral: Conceived and designed the experiments; Performed the experiments; Analyzed and interpreted the data; Contributed reagents, materials, analysis tools or data; Wrote the paper.

Funding statement

Dr. Abdul Azis Bagis was supported by Universitas Mataram [3081/UN18.1.1/PP/2021].

Data availability statement

Data associated with this study has been deposited at <https://github.com/abdulazisbagis/Workplace-spirituality>.

Declaration of interest's statement

The authors declare no conflict of interest.

Additional information

No additional information is available for this paper.

Acknowledgements

Author is thankful to Mataram Univeristy, West Nusa Tenggara Province, Indonesia, for providing research funding support.

References

- Abdelfattah, F., Al Halbusi, H., Al-Brwani, R.M., 2022. Influence of self-perceived creativity and social media use in predicting E-entrepreneurial intention. *Int. J. Innov. Stud.* 6 (3), 119–127.
- Abdullah, A.N., Saeed, A., 2019. Entrepreneurial intentions of undergraduate students in Yemen: applying the theory of planned behaviour. *Eur. J. Bus. Manag.* 11 (35), 28–34.
- Ajzen, I., 1991. The theory of planned behavior. *Organ. Behav. Hum. Decis. Process.* 34 (11), 50.
- Al-mamary, Y.H.S., Abdulrab, M., Alwaheeb, M.A., Alshammari, N.G.M., 2020. Factors Impacting Entrepreneurial Intentions Among university Students in Saudi Arabia : Testing an Integrated Model of TPB and EO.
- Al Halbusi, H., Estevez, P.J., Eleen, T., Ramayah, T., Hossain Uzir, M.U., 2020. The roles of the physical environment, social servicescape, co-created value, and customer satisfaction in determining tourists' citizenship behavior: Malaysian cultural and creative industries. *Sustainability* 12 (8), 1–23.
- Al Halbusi, H., Hassani, A., Mosconi, E., 2021. Social media technologies' use for competitive information and informational trust and their effects on innovation in industrial SMEs. In: 2021 IEEE International Conference on Technology Management, Operations and Decisions, ICTMOD 2021, (April).
- Anwar, I., Thoudam, P., Saleem, I., 2021. Role of entrepreneurial education in shaping entrepreneurial intention among university students: testing the hypotheses using mediation and moderation approach. *J. Educ. Bus.* 1–27.
- Baehr, J., 2017. The varieties of character and some implications for character education. *J. Youth Adolesc.*
- Bergmann, H., Geissler, M., Hundt, C., Grave, B., 2018. The climate for entrepreneurship at higher education institutions. *Res. Pol.* 47 (4), 700–716.
- Bienstock, J., Daniel, J., 2019. *J. Business Behav. Sci.* 31 (2).
- Bogatayeva, K., Edelman, L.F., Manolova, T.S., Osiyevskyy, O., Shirokova, G., 2019. When do entrepreneurial intentions lead to actions? The role of national culture. *J. Bus. Res.* 96, 309–321.
- Bolton, D.L., Lane, M.D., 2012. Individual entrepreneurial orientation: development of a measurement instrument. *Educ. Train.* 54 (2–3), 219–233.
- Brown, D., Dillard, J., Marshall, R.S., 2006. Documents de Treball.
- Brucaj, S., Karci, B., 2013. Workplace spirituality in higher education. *Beder J. Human.* 1 (22), 10–20.
- Butar Butar, I.D., 2018. National culture and paternalistic leadership Indonesian business context. *J. Business Entrepreneurship* 6 (2), 58–62.
- Cheng, W., Adejumo, O.O., 2021. Entrepreneurship channels and sustainable development: directions for the asian economy. *J. Bus. Econ. Manag.* 22 (3), 799–822.
- Cho, Y.H., Lee, J., 2018. Entrepreneurial Orientation, Entrepreneurial Education and Performance.
- Christensen, C., Aaron, S., Clark, W., 2003. Disruption in education. *Educ. Rev.* 38 (1), 44–54. Retrieved from: <http://er.educase.edu/∼/media/files/article-downloads/erm0313.pdf>.
- Covin, J.G., Miller, D., 2014. International entrepreneurial orientation: conceptual considerations, research themes, measurement issues, and future research directions. *Enterpren. Theor. Pract.* 38 (1), 11–44.
- De, F.M., 2021. Entrepreneurial orientation at higher education institutions: state-of-the-art and future directions. *Int. J. Manage. Educ.* 19.
- Foster, S., Foster, A., 2019. The impact of workplace spirituality on work-based learners. *Journal of Work-Applied Management* 11 (1), 63–75.
- Friedman, H.H., Friedman, L.W., 2014. Why spirituality belongs in the business curriculum. *SSRN Electron. J.*
- Garson, G.D., 2016. Partial Least Squares (PLS-SEM).
- Geaquinto, R., Paulo, R., Pinheiro, G., 2020. Organizational spirituality : concept and perspectives. *J. Bus. Ethics.* Crossman 2016).
- Godwin, J.L., Neck, C.P., D'Intino, R.S., 2016. Self-leadership, spirituality, and entrepreneur performance: a conceptual model. *J. Manag. Spiritual. Relig.* 13 (1), 64–78.
- González Canché, M.S., 2018. Nearby college enrollment and geographical skills mismatch: (Re)conceptualizing student out-migration in the American higher education system. *J. High. Educ.* 89 (6), 892–934.
- Guo, B., Aveyard, P., Fielding, A., 2008. Testing the Convergent and Discriminant Validity of the Decisional Balance Scale of the Transtheoretical Model Using the Multi-Trait Multi-Method Testing the Convergent and Discriminant Validity of the Decisional Balance Scale of the Transtheoretical Mode. (May 2014).
- Handayati, P., Wulandari, D., Eko, B., Wibowo, A., 2020. Heliyon Does entrepreneurship education promote vocational students' entrepreneurial mindset. *Heliyon* 6, e05426.
- Hassan, M., Nadeem, A., Bin, Akhter, A., 2016. Impact of workplace spirituality on job satisfaction : mediating effect of trust Impact of workplace spirituality on job satisfaction : mediating effect of trust. *Cogent Business Manag.* 12 (1).
- Hassan, M.S., Al Halbusi, H., Razali, A., Ariffin, R.N.R., Williams, K.A., 2022. The Swedish gamble: trust in the government and self-efficacy in the battle to combat COVID-19. *Curr. Psychol.*
- Hitka, M., Starchoň, P., Lorincová, S., Caba, Z., 2021. Education as a key in career building. *J. Bus. Econ. Manag.* 22 (4), 1065–1083.
- Hossain, U., Al, H., Lim, R., Jerin, I., 2020. Since January 2020 Elsevier Has Created a COVID-19 Resource Centre with Free Information in English and Mandarin on the Novel Coronavirus COVID-19. The COVID-19 Resource centre Is Hosted on Elsevier Connect, the Company's Public News and Information (January).
- Howard, A.L., 2013. Structural Equation Modeling: A Handbook of Structural Equation Modeling, pp. 37–41.
- Id, A.M., Vallanti, G., 2022. The Gender gap in Ph.D. Entrepreneurship: How Do Students Perceive the Academic Environment?, 1–15.
- Kleckner, M.J., Butz, N., 2020. Addressing undergraduate skill gaps in higher education: revisiting communication in the major course outcomes. *J. Educ. Bus.* 1–12.
- Kleijnen, J., Dolmans, D., Muijtjens, A., Willems, J., 2009. Quality in Higher Education Organisational Values in Higher Education : Perceptions and Preferences of Staff. (December 2014), pp. 37–41.
- Kumar, S., Paray, Z.A., Dwivedi, A.K., 2019. Student ' S Entrepreneurial Orientation and Intentions and Regions.
- Lackeus, M., 2015. Entrepreneurship in education: what, why, when, how. *Oecd* 68–70.
- Liu, X., Lin, C., Zhao, G., Zhao, D., 2019. Research on the effects of entrepreneurial education and entrepreneurial self-efficacy on college students' entrepreneurial intention the effect of entrepreneurial education, 10, pp. 1–9.
- Lu, Y., Lai, H., Lin, P., Kuo, S., Chen, S., Lee, P., 2022. Predicting exercise behaviors and intentions of Taiwanese urban high school students using the theory of planned behavior. *J. Pediatr. Nurs.* 62, e39–e44.
- Marion, T.J., Fixson, S.K., 2021. The transformation of the innovation process: how digital tools are changing work, collaboration, and organizations in new product development. *J. Prod. Innovat. Manag.* 38 (1), 192–215.
- Marzi, G., 2022. On the nature, origins and outcomes of over Featuring in the new product development process. *J. Eng. Technol. Manag. – JET-M* 64.
- Mat, N., Romli, R., Noor, N., 2012. Modelling workplace spirituality and teaching effectiveness for academicians in Malaysia. *Int. J. Bus. Manag. Stud.* 4 (1), 157–164. Retrieved from: http://www.sobiad.org/eJOURNALS/journal_LJBM/arihieves/2012_Vol4_n1/norazuwa_mat.pdf.
- Mukhtar, S., Wardana, L.W., Wibowo, A., Narmaditya, B.S., 2021. Does entrepreneurship education and culture promote students' entrepreneurial intention? The mediating role of entrepreneurial mindset. *Cogent Educ.* 8 (1).
- Müller, J.W., 2021. Heliyon Education and inspirational intuition – drivers of innovation. *Heliyon* 7, e07923.
- Naveed, R.T., Alhaidan, H., Halbusi, H. Al, Al-Swidi, A.K., 2022. Do organizations really evolve? The critical link between organizational culture and organizational innovation toward organizational effectiveness: pivotal role of organizational resistance. *J. Innov. Knowl.* 7 (2), 100178.
- Oliveira, A., Rua, O.L., 2018. From intention to entrepreneurial action: assessing the impact of the barriers on the creation of new organizations. *RAUSP Manag. J.* 53 (4), 507–534.
- Paço, A., Ferreira, J.M., 2013. Entrepreneurial intentions: is education enough ?
- Petchsawang, P., Duchon, D., 2009. Measuring workplace spirituality in an asian context. *Hum. Resour. Dev. Int.* 12 (4), 459–468.
- Phan, H.P., Ngu, B.H., Chi, S., Wu, L., Shih, J., Shi, S., 2021. Heliyon Life , death , and spirituality : a conceptual analysis for educational research development. *Heliyon* 7, e06971.
- Phillips, L.W., 2013. Assessing Construct Validity in Organizational Research Richard P. Bagozzi, 36, pp. 421–458 (3).
- Plopeanu, A.P., Homocianu, D., Airinei, D., 2018. Determinants of entrepreneurial proclivity of students in economics and business administration. *Econ. Comput. Econ. Cybern. Stud. Res.* 52 (3), 101–119.
- Porter, T.H., Mitchell, M.C., 2016. Spiritual institutional entrepreneurs: an introduction and examination. *J. Manag. Spiritual. Relig.* 13 (1), 50–63.
- Rania, N., Siri, A., Bagnasco, A., Aleo, G., Sasso, L., 2014. Academic climate, well-being and academic performance in a university degree course. *J. Nurs. Manag.* 22 (6), 751–760.
- Raposo, M., Paço, A., 2011. Special Issue: Entrepreneurship and Education — Links between Education and Entrepreneurial Activity, pp. 143–144.

- Rasmussen, E., Borch, O.J., 2010. University capabilities in facilitating entrepreneurship : a longitudinal study of spin-off ventures at mid-range universities. *Res. Pol.* 39 (5), 602–612.
- Ringle, C.M., Sarstedt, M., 2021. Partial Least Squares Structural Equation Modeling (PLS-SEM) Using R.
- Rubin, A., Callaghan, C.W., 2019. Heliyon Entrepreneurial orientation , technological propensity and academic research productivity. *Heliyon* 5, e02328.
- Salcedo, A.V., Blazatin, J.R., 2021. Workplacespiritualityasamediator to individualspirituality and organizational performance in a hospitality business: an evidence from hotel X, clarkfield, angelescity, pampanga, Philippines. *Int. J. Commer. Bus. Manag.* 1 (1), 21.
- Salisu, J.B., 2020. Heliyon Entrepreneurial training effectiveness , government entrepreneurial supports and venturing of TVET students into IT related entrepreneurship – an indirect-path effects analysis. *Heliyon* 6 (October), e05504.
- Shirokova, G., Osiyevskyy, O., Bogatyreva, K., 2015. Exploring the intention-behavior link in student entrepreneurship : moderating effects of individual and environmental characteristics. *Eur. Manag. J.*
- Siddoo, V., Sawattawee, J., Janchai, W., Thimukool, O., 2019. An exploratory study of digital workforce competency in Thailand. *Heliyon* 5 (5), e01723.
- Soliman, M., Di, F., Figueiredo, R., Jose, M., 2021. The impact of workplace spirituality on lecturers ' attitudes in tourism and hospitality higher education institutions. *Tourism Manag. Perspect.* 38, 100826.
- Stern, P.C., 2000. Toward a coherent theory of environmentally significant behavior. *J. Soc. Issues* 56 (3), 407–424.
- Suratno, Narmaditya, B.S., Wibowo, A., 2021. Family economic education, peer groups and students' entrepreneurial intention: the mediating role of economic literacy. *Heliyon* 7 (4), e06692.
- Taatila, V., Down, S., 2012. Measuring entrepreneurial orientation of university students. *Educ. Train.* 54 (8), 744–760.
- Taatila, V., Down, S., 2016. Education + Training Emerald Article: Measuring Entrepreneurial Orientation of University Students (April).
- Uzir, M.U.H., Al Halbusi, H., Thurasamy, R., Thiam Hock, R.L., Aljaberi, M.A., Hasan, N., Hamid, M., 2021. The effects of service quality, perceived value and trust in home delivery service personnel on customer satisfaction: evidence from a developing country. *J. Retailing Consum. Serv.* 63, 102721.
- Vamvaka, V., Stoforos, C., Palaskas, T., Botsaris, C., 2020. Attitude toward entrepreneurship, perceived behavioral control, and entrepreneurial intention: dimensionality, structural relationships, and gender differences. *J. Innov. Entrepreneurship* 9 (1).
- Waggoner, M.D., 2016. Spirituality and contemporary higher education. *J. Coll. Character* 17 (3), 147–156.
- Wahidmurni, W., Indah, A., Alfiana, Y., Abdussakir, A., 2020. Entrepreneurial intention of university students and the affecting factors. *Libr. Philos. Pract.* 1–14.
- Wardana, L.W., Narmaditya, B.S., Wibowo, A., Fitriana, Saraswati, T.T., Indriani, R., 2021. Drivers of entrepreneurial intention among economics students in Indonesia. *Entrepreneurial Business Econ. Rev.* 9 (1), 61–74.
- Williams, P., Allen, S., 2014. Faculty perspectives on the inclusion of spirituality topics in nonsectarian leadership and management education programs. *Int. J. Manag. Educ.* 12 (3), 293–303.
- Wishnu, L., Shandy, B., Wibowo, A., Martha, A., Aris, N., Harwida, G., Nur, A., 2020. Heliyon the impact of entrepreneurship education and students' entrepreneurial mindset : the mediating role of attitude and self-ef fi cacy. *Heliyon* 6, e04922.

Building Student's Entrepreneurial Orientation Through Entrepreneurial Intention and Workplace Spirituality

ORIGINALITY REPORT

13%

SIMILARITY INDEX

14%

INTERNET SOURCES

7%

PUBLICATIONS

4%

STUDENT PAPERS

MATCH ALL SOURCES (ONLY SELECTED SOURCE PRINTED)

4%

★ www.tandfonline.com

Internet Source

Exclude quotes On

Exclude matches < 25 words

Exclude bibliography On

Building Student's Entrepreneurial Orientation Through Entrepreneurial Intention and Workplace Spirituality

GRADEMARK REPORT

FINAL GRADE

/0

GENERAL COMMENTS

Instructor

PAGE 1

PAGE 2

PAGE 3

PAGE 4

PAGE 5

PAGE 6

PAGE 7

PAGE 8

PAGE 9
