

# ICACSYS\_LiDAR

*by* Ario Husodo

---

**Submission date:** 08-Apr-2023 11:38PM (UTC-0500)

**Submission ID:** 2059360327

**File name:** DAR\_Point\_Cloud\_Building\_Segmentation\_Progress\_and\_Challenge.pdf (1.15M)

**Word count:** 4739

**Character count:** 25095

# Outdoor LiDAR Point Cloud Building Segmentation: Progress and Challenge

Ahmad Gamal<sup>1</sup>, Ario Yudo Husodo<sup>2</sup>, Grafika Jati<sup>2</sup>, Machmud R Alhamidi<sup>2</sup>, M. Anwar Ma'sum<sup>2</sup>, Ronni Ardianto<sup>3</sup>, and Wisnu Jatmiko<sup>2</sup>

<sup>1</sup>Faculty of Engineering, Universitas Indonesia, Depok-West Java, Indonesia

<sup>2</sup>Faculty of Computer Science, Universitas Indonesia, Depok-West Java, Indonesia

<sup>3</sup>PT. Pangripta Geomatika Indonesia (UAV LiDAR Specialist), Jakarta, Indonesia  
ahmad.gamal@eng.ui.ac.id

**Abstract**— The demand for 3D modeling using LiDAR as the primary source for observing, planning, and managing urban areas has increased. Using LiDAR data improves the accuracy of the modeling so that it can be used for policy determination and infrastructure planning. Various kinds of research on LiDAR data have been carried out, one of which is indoor and outdoor LiDAR segmentation. For outdoor cases, LiDAR data can be obtained from two points of view, namely ground view and aerial view. In this paper, we discuss the advancements and challenges of LiDAR 3D modeling in building segmentation that we have carried out. We collect LiDAR data with unmanned aerial vehicles. We use several algorithms such as PointNet and the Dynamic Graph Convolutional Neural Network variations to group structures from LiDAR data. The result is that the proposed method can segment buildings, surfaces, and vegetation well. The average accuracy produced for the Kupang and Depok datasets reaches 70%-80%.

**Keywords**—3D Modeling; LiDAR; Building Segmentation; PointNet; Dynamic Graph Convolutional Neural Network

## I. INTRODUCTION

Geospatial data management has an essential role in realizing good governance in an area [1]. Urban areas that are well organized and follow the master plan enable government agencies, companies, and policymakers to implement several tasks such as disaster management, recording, and assessing urban growth efficiently and accurately [2]. In this way, local revenue can be maximized. One of the most significant contributors to regional income is land and building taxes. With the city's rapid development, the local revenue due to taxes should also be getting bigger. However, ironically, the faster the city's growth, the more vulnerable it will be to violations in it. One of the violations is a violation of spatial planning, which causes the object tax selling value (NJOP) not to match reality so that local revenue cannot be maximized. The current solution is only door-to-door monitoring, which is inefficient and takes long [3].

This problem does not only affect local revenue but can also damage the ecosystem. Figure 1 shows the presence of settlements in the green area. The consequences of this violation are that the buildings are not recorded, the lack of green open spaces to reduce the absorption of rainwater, which impacts the flood disaster, and the destruction of river and lake ecosystems that should be free from household waste. In addition, another

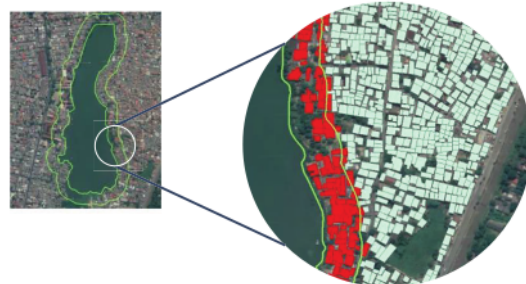

Fig. 1. Settlement in green area can harm the ecosystems.

critical problem is the mismatch between data from one agency to another due to the use of different sensors. This can make it challenging to get accurate information.

Based on the above problems, an accurate, updated, and integrated geospatial information system is needed so that every agency that needs it can refer to the application, the implication of which is to maximize regional income. The first thing that can be done is to use remote sensing technology, which is more accurate for data collection. One of them is the use of Light Detection and Ranging (LiDAR). LiDAR can provide 3-dimensional imaging information, which can then be used to make accurate digital maps on a scale of 1: 10,000. Compared to existing online maps owned by the Government, this scale has a higher accuracy [4]–[13]. With this high accuracy, information on estimated land prices can be carried out until the parcel stage. In addition to the accuracy of the land area, LiDAR is also able to provide information regarding the volume of buildings standing on the land.

Due to the capabilities of LiDAR, the demand for 3D modeling using it as the primary source for observing, planning, and managing urban areas has increased. This model can be used for policy determination and infrastructure planning. A few years back, various kinds of research on LiDAR data have been carried out, such as building extraction [14], urban analysis [15], and tree modeling [16], [17]. Besides, the tremendous potential for large-scale geospatial data processing and research in image processing [11]. LiDAR data presents its challenges. One of them is for semantic segmentation tasks because of their high resolution [18]. This paper describes the progress and challenges

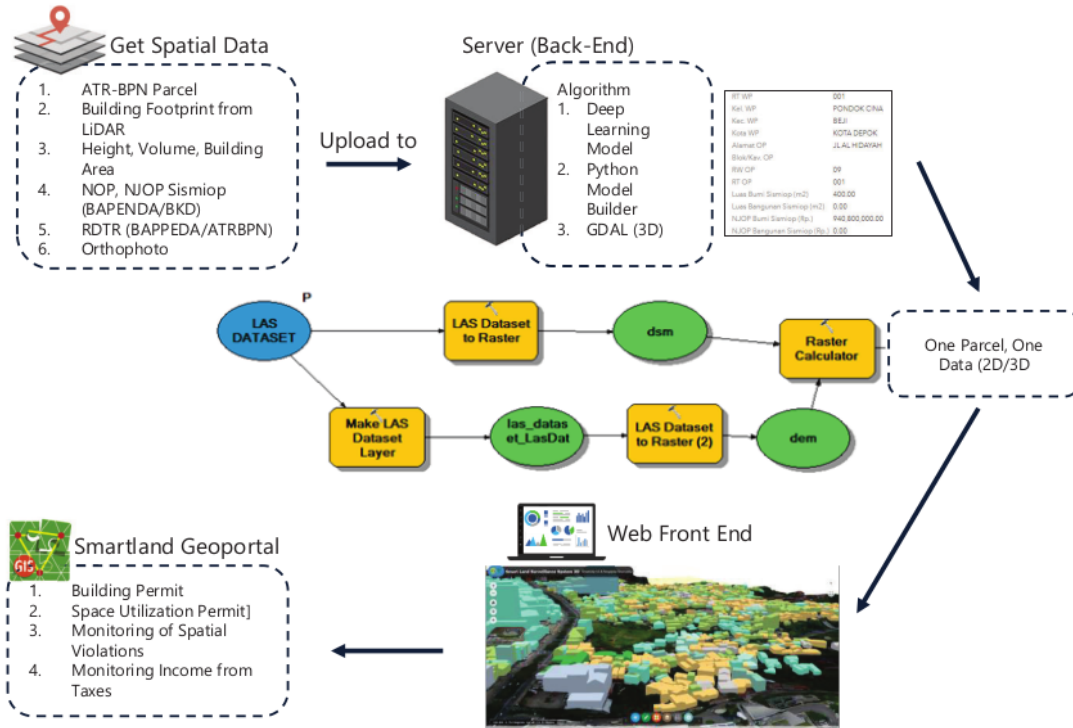

Fig. 2. Smart Land Surveillance (SLSS) business process.

we face in conducting research using lidar data for the geospatial information system that we have built.

The remainder of this paper is as follows. In section 2, before we talk about our progress, first we describe our developed system. After that, we discuss the progress we have made in semantic segmentation using outdoor LiDAR data. Section 4 contains the performance and evaluation of our methods. The last section explains the challenge of SLSS and then the conclusion of this paper.

## II. SMART LAND SURVEILLANCE SYSTEM (SLSS)

The Smart Land Surveillance System (SLSS) business process is shown in Figure 2. The SLSS that are built consists of two components, namely back-end and front-end. The process generally consists of data pre-processing, 3D modeling, spatial adjustment, etc. The front-end will display a geospatial information system consisting of building information, space utilization, spatial violations, and taxes. With this applied technology, it can benefit both the community and the Government. This technology will make it easier for the district to adapt to economic changes that occur regularly. With the automation of land technology, people can find out information about market price estimates more quickly, carry out activities to buy and sell private land assets, and other personal needs such as the distribution of inheritance assets or the use of land assets as collateral start a business.

For the Government, three aspects can be utilized from this technology. The first is the aspect of supervision. Supervision, in this case, is the supervision of the selling value of objects of land and building tax and market prices.

The second benefit is the aspect of control. With information about land parcels and building volumes, the Government can enforce building regulations more effectively. The Government can impose sanctions in the form of additional taxes or other sanctions on buildings that have a volume greater than the volume of buildings permitted under the Building Permit. City development plans can be monitored and controlled more effectively with this land and building information automation technology.

The third benefit is the aspect of regional revenue through taxes. Through tax sanctions imposed on violators of building regulations, the Government can obtain additional income from taxes for the local budget. With tax sanctions imposed, this is more assertive and broader. It is expected that the regulations determined by the Government can run regional development planning.

## III. METHOD

### A. Data Acquisition

Our research dataset is obtained from our partner PT. Pangripta Geomatika Indonesia (PGI), one of Indonesia's companies, actively collects LiDAR data. The data is a LiDAR

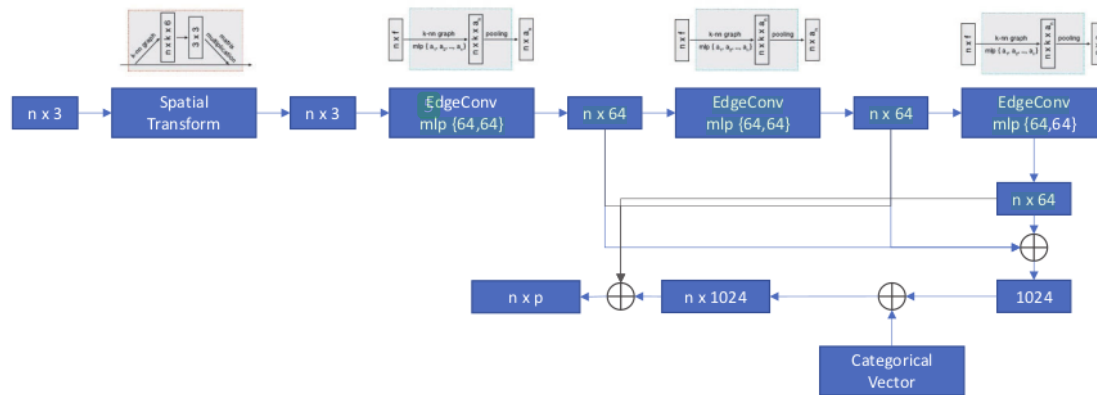

Fig. 3. DGCNN architecture.

dataset from sensing results in the Oesapa village, Kupang City, East Nusa Tenggara Province, Indonesia, and Margonda, Depok City, West Java Province, Indonesia. The area has various objects representing the land cover, such as vegetation, roads, houses, buildings, and several types of trees of different sizes. The dataset was collected using the LiDAR YellowScan Mapper 2016. This study's raw LiDAR data includes four regions with the LAS file format (LASer). LAS files are the binary format to store airborne LiDAR data in the industry standard.

We group them into classes of building, trees, and ground class from various land cover components. The LiDAR Kupang dataset comprises a voxel point cloud with an X, Y, and Z coordinate value component and is embedded with the RGB color component. The X, Y, and Z components have a measured position value and RGB data range 0 - 65535.

#### B. Pre-processing

The raw LiDAR dataset is point cloud data in a LASER or \*.las file format. The file extension format is a format generally used for storing point cloud data gathered from LiDAR sensors. However, this format is not familiarly used in computing processes, so that it is mandatory to convert it to a more straightforward format for humans to understand (readable format). We restore data to TXT from LAS format utilizing the LAS tools application, particularly the las2txt library. LAS tools are used in this study because it does not change the point cloud data's value. Then, the data that has been converted into text is separated into some regions. The divided areas are used to process  $k$ -fold cross-validation.

The dataset is already in text format; then, we divided it into six regions, as shown in Figure 3. We consider dividing the dataset into six areas because the total number of point clouds is about six million points, with nearly 1 million points for each area. The data division is helpful for training data and testing process with  $k$ -fold cross-validation method. This method allows us to divide the data into  $k$  pieces of equal data subsets [38]. After the data is divided, the segmentation model will be created  $k$  times, each using a different data subset for the test data, with the remaining  $k-1$  data subsets as training data. With

this method, it can be ascertained that each data subset will be used once as test data and will be used as training data  $k-1$  times. Model performance can be obtained by averaging the performance of each of the models. In this study, 6-fold cross-validation was used, meaning that one dataset area was tested with five other datasets.

The following dataset pre-processing is annotating each land cover component. The annotation process is done by dividing the constituent parts of the area and naming them based on their class name, as shown in Figure 4. The annotated components of the voxels include building, ground, and tree classes. Annotations are done using the MeshLab application. Figure 5 presents the result of the annotation process of the dataset that we use as the ground truth containing building (red color), tree (green color), and ground (blue color). Then we carried out random sampling in each region. A random sample is carried out by dividing an area into some smaller parts (blocks). Every block has specific  $M \times M \times H$  dimensions.  $M$  represents the block's length and width dimensions from the X and Y axes, while  $H$  for the height of the area sampled in the Z coordinate. On each block,  $N$  points are taken that are used as training data and testing data. Sampling was carried out with a block size of  $5 \times 5$  with 256 points and  $10 \times 10$  with 4096 points.

#### C. PointNet

PointNet is the pioneer method in 3D point clouds classification and segmentation. Originally the method was proposed to segment 3D point cloud indoor data such as a table, chair, wall, etc. [19]. However, along with the fast development of 3D segmentation, the method becomes the benchmark and base network for the later methods. The method takes point clouds as input, where a point cloud has three coordinate attributes (x,y,z) and color (r,g,b). The method utilizes multi-layer perceptron (MLP) and feature transform (t-net) to generate global features. Then the global feature is processed by segmentation network. The network was later modified into PointNet++ [20]. PointNet++ is an enhanced architecture of PointNet by using hierarchical feature learning. The method can produce a deep architecture both for segmentation and classification.



TABLE 1. PERFORMANCE OF 3D LIDAR SEGMENTATION OF KUPANG DATA.

Dataset	Accuracy (%)		
	PointNet	DGCNN	Modified DGCNN
Area_1	82.27	84.81	88.28
Area_2	48.49	63.41	64.77
Area_3	45.91	64.33	66.84
Area_4	71.48	64.69	72.79
Area_5	73.10	72.03	74.32
Area_6	64.26	86.08	86.30
Average	65.08	72.56	75.55

TABLE 2. PERFORMANCE DGCNN ON 3D LIDAR SEGMENTATION OF DEPOK DATA.

Area	Accuracy (%)	Precision (%)	Recall (%)	F-Score (%)	IoU (%)
Area_1	89	90	86	87	78
Area_2	91.5	90	89	89	81
Area_3	85.2	79	81	80	68
Area_4	84.3	79	74	76	63

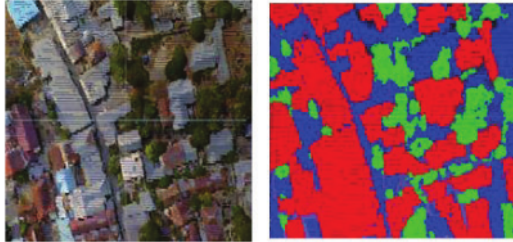

Fig. 4. Visual analysis of 3D Lidar Segmentation of Kupang Data.

#### D. Dynamic Graph Convolutional Neural Network

Dynamic Graph Convolutional Neural Network (DGCNN) is a point-based deep neural network architecture for 3D-point clouds segmentation and classification. The main idea of the DGCNN is to utilize edge convolution instead of regular convolution used in the image [21]. Figure 3 shows the architecture of DGCNN. The edge convolution represents the point clouds in a graph view. Therefore, DGCNN considers the relation of a point cloud and nearby point clouds as necessary information. The method takes point clouds as input. Before convolution, the method processes the point clouds by using a spatial transform mechanism. The method uses several layers of edge convolutions as feature extraction of the network. The method then uses multiple layer perceptron (MLP) as a classification module. The experiment on the 3D point clouds benchmark dataset shows that DGCNN outperformed PointNet and PointNet++.

#### IV. PERFORMANCE EVALUATION

In this section, we discuss the performance of the 3D LIDAR point clouds segmentation of cities Kupang and Depok,

TABLE 3. PERFORMANCE DSM ON 3D LIDAR SEGMENTATION OF DEPOK DATA.

Area	Accuracy (%)	Precision (%)	Recall (%)	F-Score (%)	IoU (%)
Area_1	54.01	81	54	64	55
Area_2	60.5	87	61	71	63
Area_3	52.03	78	52	62	51
Area_4	51.06	76	51	61	48

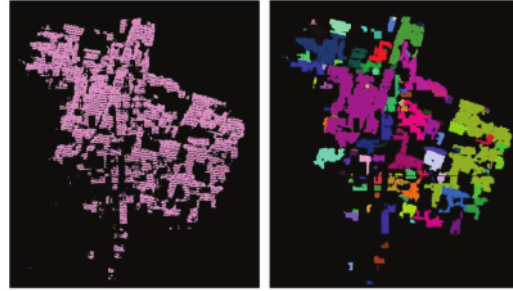

Fig. 5. Visual analysis of 3D Lidar Segmentation of Depok Data.

Indonesia. The segmentation is conducted by several methods, i.e., PointNet, DGCNN, and modified DGCNN.

#### A. Performance of 3D Lidar Segmentation of Kupang Data

In this scenario, the 3D LIDAR data is labeled into 3 class categories, i.e., ground, building, and vegetation. The dataset is divided into 6-folds, where each fold represents an area. In the scenario, we evaluated three models, i.e., PointNet [22], DGCNN, and enhanced DGCNN with Mahalanobis distance [23], [24]. The enhanced DGCNN replaces the distanced metrics of K-NN in the edge convolution from Euclidean distance into Mahalanobis distance. The experiment result shows that the PointNet method achieved 65.08% accuracy on average from 6 areas, while DGCNN achieved better accuracy with 72.56% accuracy. The modified DGCNN achieves better accuracy than the original DGCNN and PointNet, with 75.55% accuracy on average. The detailed information of each area is presented in the table below. We can also see the visual comparison of the segmentation in Figure 4.

#### B. Performance of 3D Lidar Segmentation of Depok Data

We labeled the 3D LIDAR is labeled into 2 class categories, i.e., building and non-building. In this scenario, the dataset is divided into 4-folds, where each fold represents an area. Same as in the previous scenario, we evaluated two models, i.e., DGCNN and digital surface model (DSM) [25]. In this scenario, we conducted building clustering to identify or separate a building from nearby buildings. We utilized euclidean-based clustering to separate each building object.

We utilized precision, recall, f-score, the intersection of union (IoU), and accuracy metrics in this scenario. Tables 2 and 3 show the result of Depok point clouds segmentation by using DGCNN and DSM method. The tables show that in area 2, the DGCNN achieved good performance with 91. % Accuracy, 90% precision, 89% recall, 89% F-score, and 81% IoU. However, in

area 4, the performance of DGCNN is not good, with 84% accuracy, 79% precision, 74% recall, 76% f-score, and 63% IoU. While in area 1 and area 3, the performance of DGCNN is moderate between its performance in area 2 and area 4. Table 1 also shows that overall, the DGCNN method achieved better performance than the DSM method. Looking to all areas, the DGCNN achieved better performance than DSM measure by all metrics, i.e., accuracy, precision, recall, f-score, and IoU. The visual result of the Depok Lidar segmentation is shown in figure 5.

## V. CHALLENGE

### A. Segmentation

We are eager to solve several challenges in the future study for the segmentation task in Lidar data. One of the hot challenges in Lidar point clouds segmentation is improving the segmentation performance. From the analysis we have been conducted, the performance of the deep learning method is still below 90% overall, both in 3-classes (ground, building, vegetation) scenario and in 2 classes (building, non-building scenario). Looking from the experiments log, we get the insights that the model needs to be improved both from its architecture and learning method. The model cannot achieve 100% training accuracy in the current condition, no matter how much learning epoch we have run.

The other challenge in segmentation is classifying the overlapped objects, e.g., building with tree (vegetation). This challenge becomes vital to solving because the correct classifications of the point clouds affect building segmentation. Furthermore, it will affect the shape of a segmented building. While looking at the current condition, it is common to have trees near the buildings in Indonesia.

### B. Building instance clustering

The other significant challenge in this study is clustering building instances. The main goal of the application is per-building object segmentation. Therefore, we need to develop an algorithm to separate building objects and other building objects. This challenge is difficult to detect how many buildings in an area and build precise position and dimension, i.e., length, width, and height. And shape. The wrong building instance clustering will affect the wrong calculated dimensions. The incorrect dimension calculation will produce inaccurate building volumetric calculation and affect tax enforcement for the owner. Therefore, it is vital to have high accuracy building instance clustering to separate building objects from other building objects accurately and precisely.

Based on our study, distance-based clustering did not achieve good performance since several cases produce wrong building separation, where two buildings are detected as one building. Furthermore, the Euclidean distance is not adaptive to the variation of distance to the other buildings. In our post-study analysis, density-based clustering like DBSCAN offers more accurate building instances clustering. However, it requires precise segmentation to separate building and non-building point clouds prior to the building instances clustering phase.

### C. Spatial Adjustment

The resulting precision geometry from lidar will be extracted and then deduced with cadastral data. The data consist of land ownership, building ownership, and taxes sourced from Government. We fuse data from lidar and cadastral data to determine the difference in volume between building objects identified in the field and the values recorded in the cadastral data.

We fuse two parcel maps using spatial adjustment. Spatial adjustment is placing or correctly positioning data spatially to its actual position on the earth's surface. We consider the parcel from lidar as a destination map because it describes the current conditions in an area. The cadastral map from the Government is referred to as the source map. This source map is spatially adjusted to the destination map.

In the spatial adjustment process, we need to understand the characteristics of the errors that occur between the two source and destination maps. When the error is consistent, the direction & distance is a linear transformation categorized as a simple solution. Meanwhile, when the error is non-linear, then we need a control point. Currently, the control point is defined manually because non-linear error generates four challenges, namely:

1. Differences in scale, different angles, and shifts in position, but the data dimensions (aspect ratio) are the same
2. Differences in scale, angle differences, and shifts in position with different data dimensions (skew)
3. Dimensional differences in all directions.
4. Difference number of parcels between the two maps.

The control point will be utilized in the transformation phase. There are several choices of transformation methods such as similarity transform, affine transform, projective transform, and rubber-sheet. It is necessary to develop an automatic control point determination method for the feature work to handle the four challenges above. Automatically can speed up the process and save time and costs in the Smart Land Surveillance System.

## VI. CONCLUSION

Technology growth makes it easier for people to access information quickly. Information becomes a basic need that is needed as a basis for determining decisions in everyday life. The more detailed information obtained by someone, the more valuable the information is. The importance of the accuracy of this information encourages the need to add various types of applied technology that the public can access. One of them is used technology that can quickly provide information regarding building volume and estimated building and land values.

Technology about land information and buildings is needed because the land is an important asset, especially in economic aspects. Land and buildings are fixed assets that can be used for the production process or other parties for several periods. Land and building assets can be used as investment assets and can provide income for the owner. People need to know the value of the land and building assets they have to market prices.

We successfully implement LiDAR point cloud segmentation using PointNet and DGCNN. Segmentation results show that DGCNN gives a better performance compared to PointNet in 3 classes point cloud. For future works, we improve segmentation performance using a better clustering approach and increase the number of classes of the segmented object.

8

#### ACKNOWLEDGMENT

This work is supported by the National Research and Innovation Agency (BRIN) with the research title "Pengembangan Sistem Big Data Perkotaan Berbasis Kejurdasan Buatan untuk Analisis Kepatuhan Bangunan Terhadap Rencana Tata Ruang Wilayah dan Perijinan Pembangunan dalam Rangka Peningkatan Pendapatan Daerah dan Perlindungan Kualitas Lingkungan Perkotaan". The grant number is 26/E1/PRN/IV/2021. We also thank to PT. Pangripta Geomatika Indonesia (PGI) for providing the LiDAR dataset.

#### REFERENCES

- [1] Q. Man, P. Dong, X. Yang, Q. Wu, and R. Han, "Automatic Extraction of Grasses and Individual Trees in Urban Areas Based on Airborne Hyperspectral and LiDAR Data," *Remote Sens.*, vol. 12, no. 17, 2020, doi: 10.3390/rs12172725.
- [2] A. Wibisono, W. Jatmiko, H. A. Wisesa, B. Hardjono, and P. Mursanto, "Traffic big data prediction and visualization using Fast Incremental Model Trees-Drift Detection (FIMT-DD)," *Knowledge-Based Syst.*, vol. 93, pp. 33–46, 2016, doi: 10.1016/j.knsys.2015.10.028.
- [3] C. Yi *et al.*, "Urban building reconstruction from raw LiDAR point data," *Comput. Des.*, vol. 93, pp. 1–14, 2017, doi: <https://doi.org/10.1016/j.cad.2017.07.005>.
- [4] W. Y. Yan, A. Shaker, and N. El-Ashmawy, "Urban land cover classification using airborne LiDAR data: A review," *Remote Sens. Environ.*, vol. 158, pp. 295–310, 2015, doi: <https://doi.org/10.1016/j.rse.2014.11.001>.
- [5] N. Ekhtari, C. Glennie, and J. C. Fernandez-Diaz, "Classification of Airborne Multispectral Lidar Point Clouds for Land Cover Mapping," *IEEE J. Sel. Top. Appl. Earth Obs. Remote Sens.*, vol. 11, no. 6, pp. 2068–2078, 2018, doi: 10.1109/JSTARS.2018.2835483.
- [6] F. Azevedo *et al.*, "LiDAR-Based Real-Time Detection and Modeling of Power Lines for Unmanned Aerial Vehicles," *Sensors*, vol. 19, no. 8, 2019, doi: 10.3390/s19081812.
- [7] M. A. Wulder *et al.*, "Lidar sampling for large-area forest characterization: A review," *Remote Sens. Environ.*, vol. 121, pp. 196–209, 2012, doi: <https://doi.org/10.1016/j.rse.2012.02.001>.
- [8] C.-W. Peng, C.-C. Hsu, and W.-Y. Wang, "Cost Effective Mobile Mapping System for Color Point Cloud Reconstruction," *Sensors*, vol. 20, no. 22, 2020, doi: 10.3390/s20226536.
- [9] S. Wu, C. Wen, H. Luo, Y. Chen, C. Wang, and J. Li, "Using mobile LiDAR point clouds for traffic sign detection and sign visibility estimation," in *2015 IEEE International Geoscience and Remote Sensing Symposium (IGARSS)*, 2015, pp. 565–568, doi: 10.1109/IGARSS.2015.7325826.
- [10] F. Poux and R. Billen, "Voxel-based 3D Point Cloud Semantic Segmentation: Unsupervised Geometric and Relationship Featuring vs Deep Learning Methods," *ISPRS Int. J. Geo-Information*, vol. 8, no. 5, 2019, doi: 10.3390/ijgi8050213.
- [11] R. Wang, J. Peethambaran, and D. Chen, "LiDAR Point Clouds to 3-D Urban Models: A Review," *IEEE J. Sel. Top. Appl. Earth Obs. Remote Sens.*, vol. 11, no. 2, pp. 606–627, 2018, doi: 10.1109/JSTARS.2017.2781132.
- [12] P. Babahajani, L. Fan, J. Kämäräinen, and M. Gabbouj, "Urban 3D segmentation and modelling from street view images and LiDAR point clouds," *Mach. Vis. Appl.*, vol. 28, pp. 679–694, 2017.
- [13] M. Salman and S. E. Yüksel, "Fusion of hyperspectral image and LiDAR data and classification using deep convolutional neural networks," in *2018 26th Signal Processing and Communications Applications Conference (SIU)*, 2018, pp. 1–4, doi: 10.1109/SIU.2018.8404199.
- [14] Y. Li, L. Ma, Z. Zhong, D. Cao, and J. Li, "TGNet: Geometric Graph CNN on 3-D Point Cloud Segmentation," *IEEE Trans. Geosci. Remote Sens.*, vol. 58, no. 5, pp. 3588–3600, 2020, doi: 10.1109/TGRS.2019.2958517.
- [15] Q. Zhao, R. Reynolds, C. Wang, and E. A. Wentz, "A multidimensional urban land cover change analysis in Tempe, AZ," May 2019, doi: 10.1109/JURSE.2019.8808957.
- [16] Z. Chen and B. Gao, "An Object-Based Method for Urban Land Cover Classification Using Airborne Lidar Data," *IEEE J. Sel. Top. Appl. Earth Obs. Remote Sens.*, vol. 7, no. 10, pp. 4243–4254, 2014, doi: 10.1109/JSTARS.2014.2332337.
- [17] C.-S. Lo and C. Lin, "Growth-Competition-Based Stem Diameter and Volume Modeling for Tree-Level Forest Inventory Using Airborne LiDAR Data," *IEEE Trans. Geosci. Remote Sens.*, vol. 51, no. 4, pp. 2216–2226, 2013, doi: 10.1109/TGRS.2012.2211023.
- [18] Y. Sun, X. Zhang, Q. Xin, and J. Huang, "Developing a multi-filter convolutional neural network for semantic segmentation using high-resolution aerial imagery and LiDAR data," *ISPRS J. Photogramm. Remote Sens.*, vol. 143, pp. 3–14, 2018, doi: <https://doi.org/10.1016/j.isprsjprs.2018.06.005>.
- [19] C. R. Qi and L. J. Guibas, "PointNet : Deep Learning on Point Sets for 3D Classification and Segmentation."
- [20] C. R. Qi, L. Yi, H. Su, and L. J. Guibas, "PointNet ++ : Deep Hierarchical Feature Learning on Point Sets in a Metric Space," no. Nips, 2017.
- [21] Y. Wang, Y. Sun, Z. Liu, S. E. Sarma, M. M. Bronstein, and J. M. Solomon, "Dynamic Graph CNN for Learning on Point Clouds." 2019.
- [22] A. Bayu, "Semantic Segmentation of Lidar Point Cloud in Rural Area," *2019 IEEE Int. Conf. Commun. Networks Satell.*, pp. 73–78, 2019.
- [23] N. Hamid, A. Wibisono, A. Gamal, R. Ardianto, and W. Jatmiko, "Adaptive Update in Deep Learning Algorithms for LiDAR Data Semantic Segmentation," in *2020 IEEE Region 10 Symposium (TENSYP)*, 2020, pp. 1038–1041, doi: 10.1109/TENSYP50017.2020.9230926.
- [24] N. Hamid, A. Wibisono, M. A. Ma, A. Gamal, R. Ardianto, and A. M. Arymurthy, "3D Edge Convolution in Deep Neural Network Implementation for Land Cover Semantic Segmentation of Airborne LiDAR Data," *2019 4th Asia-Pacific Conf. Intell. Robot Syst.*, pp. 216–220, 2019.
- [25] A. Gamal *et al.*, "Automatic LiDAR building segmentation based on DGCNN and euclidean clustering," *J. Big Data*, vol. 7, no. 1, p. 102, 2020, doi: 10.1186/s40537-020-00374-x.



# ICACSYS\_LiDAR

---

## ORIGINALITY REPORT

---

10%

SIMILARITY INDEX

5%

INTERNET SOURCES

9%

PUBLICATIONS

3%

STUDENT PAPERS

---

## PRIMARY SOURCES

---

- |   |  |    |
|---|--|----|
| 1 | Submitted to Universitas Indonesia<br>Student Paper  | 2% |
| 2 | Nur Hamid, Ari Wibisono, Ahmad Gamal, Ronni Ardhianto, Wisnu Jatmiko. "Adaptive Update in Deep Learning Algorithms for LiDAR Data Semantic Segmentation", 2020 IEEE Region 10 Symposium (TENSYMP), 2020<br>Publication | 2% |
| 3 | Ahmad Gamal, Ari Wibisono, Satrio Bagus Wicaksono, Muhammad Alvin Abyan et al. "Automatic LIDAR building segmentation based on DGCNN and euclidean clustering", Journal of Big Data, 2020<br>Publication               | 1% |
| 4 | "Table of Content", 2021 International Conference on Advanced Computer Science and Information Systems (ICACSYS), 2021<br>Publication  | 1% |
| 5 | arxiv.org<br>Internet Source   | 1% |
-



6	Naili Suri Inthizami, M. Anwar Ma'sum, Machmud R. Alhamidi, Ahmad Gamal, Ronni Ardianto, Kurnianingsih, Wisnu Jatmiko. "Flood video segmentation on remotely sensed UAV using improved Efficient Neural Network", ICT Express, 2022 Publication	<1 %
7	kth.diva-portal.org Internet Source	<1 %
8	thesai.org Internet Source	<1 %
9	deepai.org Internet Source	<1 %
10	Randhi Atiqi, Muhammad Dimyati, Ahmad Gamal, Rizki Pramayuda. "Appraisal of Building Price in Urban Area Using Light Detection and Ranging (LiDAR) Data in Depok City", Land, 2022 Publication	<1 %
11	mdpi-res.com Internet Source	<1 %
12	uilis.unsyiah.ac.id Internet Source	<1 %
13	www.mdpi.com Internet Source	<1 %

14

Nur Hamid, Ari Wibisono, M. Anwar Ma'sum, Ahmad Gamal, Roni Ardhianto, Aniati Murni Arymurthy, Wisnu Jatmiko. "3D Edge Convolution in Deep Neural Network Implementation for Land Cover Semantic Segmentation of Airborne LiDAR Data", 2019 4th Asia-Pacific Conference on Intelligent Robot Systems (ACIRS), 2019

Publication

&lt;1 %

15

"Advances in Computer Vision", Springer Science and Business Media LLC, 2020

Publication

&lt;1 %

16

Fangyu Liu, Shuaipeng Li, Liqiang Zhang, Chenghu Zhou, Rongtian Ye, Yuebin Wang, Jiwen Lu. "3DCNN-DQN-RNN: A Deep Reinforcement Learning Framework for Semantic Parsing of Large-Scale 3D Point Clouds", 2017 IEEE International Conference on Computer Vision (ICCV), 2017

Publication

&lt;1 %

Exclude quotes On

Exclude matches &lt; 3 words

Exclude bibliography On

# ICAC SIS\_LiDAR

---

GRADEMARK REPORT

---

FINAL GRADE

**/0**

GENERAL COMMENTS

**Instructor**

---

PAGE 1

---

PAGE 2

---

PAGE 3

---

PAGE 4

---

PAGE 5

---

PAGE 6

---