

PAPER • OPEN ACCESS

Cover

To cite this article: 2020 *J. Phys.: Conf. Ser.* **1569** 011002

View the [article online](#) for updates and enhancements.

You may also like

- [Peer review statement](#)

- [Peer review statement](#)

- [Committees](#)



 **245th ECS Meeting**
San Francisco, CA
May 26–30, 2024

 **PRiME 2024**
Honolulu, Hawaii
October 6–11, 2024

Bringing together industry, researchers, and government across 50 symposia in electrochemistry and solid state science and technology

Learn more about ECS Meetings at
<http://www.electrochem.org/upcoming-meetings>

 **Save the Dates for future ECS Meetings!**

Preface for ICST 2019

It is our pleasure to welcome you to the International Conference on Science and Technology (ICST 2019) in Surabaya, Indonesia. A major goal and feature of ~~it~~this conference is to bring academic scientists, engineers, industry researchers together to exchange and share their experiences and research results about the most notable aspects of science and technology research, and discuss the practical challenges encountered and the solutions adopted.

ICST is a scientific forum to discuss the development and the latest research on exact science, engineering and technology. The following topics of this conference are Physical Sciences and Chemistry, Mathematics and Statistics, Informatics and Computer Science, Aerospace Engineering, Biomedical Engineering, Chemical Engineering, Civil Engineering, Computer Engineering, Electrical Engineering and Electronics, Power and Energy Engineering, Environmental Engineering, Geological and Geophysical Engineering, Industrial Engineering, Manufacturing and Mechanical Engineering, Engineering Physics and Materials Engineering, Mining and Petroleum Engineering. Technology-based applications such as learning media for education can also be accepted at this Conference.

Strong support and active participation of authors have made the ICST 2019 a record-breaking event. It is a wonderful to have more than 300 papers or speakers from different countries and universities around the world representing various issues from multidisciplinary perspective. Each contributed paper was refereed before accepted for publication in this proceedings. The papers were accepted for publication based on their interest, relevance, innovation and application to the related fields. Hopefully by using the IOP Journal of Physics Conference Series as publisher, ICST 2019 will be sounded all around the world, moreover the papers that will be published could give positive results for further research.

ICST 2019 program have taken place over 3 days, 17 to 19 October. The first two days of the conference took place at the Sheraton Surabaya Hotel & Towers. On the third day, on Saturday, we have traveled to Madura Island, studied Madura Culture, saw directly the "Karapan Sapi" (traditional race bull) and enjoyed the special cuisine of Madura. That is why the theme of this conference is "Industrial Revolution 4.0: The opportunities and challenges in elevating local resources contribute to develop a better world".

We would like to thank the organization staff, the members of the program committees and reviewers. Special thanks to committee from Universitas Trunojoyo Madura, Universitas Negeri Surabaya, Politeknik Negeri Bali, Universitas Pembangunan Nasional "Veteran", Jawa Timur, Universitas Negeri Makassar, Universitas Negeri Manado, Politeknik Negeri Jember, Universitas Khairun, Universitas Musamus Merauke, Universitas Pembangunan Nasional "Veteran", Jakarta, Universitas Kadiri, Universitas Wijaya Kusuma Surabaya, and Universitas Bahaudin Madura. They have worked very hard in reviewing papers and making valuable suggestions for the authors to improve their work. We also would like to express our gratitude to the external reviewers, for providing extra help in the review process, and the authors for contributing their research result to the conference. Special thanks go to IOP Journal of Physics Conference Series Editor Team.



We look forward to seeing all of you next year at ICST 2020, in Makassar, Indonesia.

Rifky Yusron

Conference Publication Chair

Table of contents

Volume 1569

2020

◀ Previous issue Next issue ▶

International Conference on Science and Technology 2019 17-18 October 2019, Surabaya, Indonesia

Accepted papers received: 27 May 2020

Published online: 23 July 2020

Open all abstracts

Industrial Engineering

OPEN ACCESS 032001

Study on kefir grain concentration and the different length of storage on the physicochemical of goat milk kefir

A C Dewi, A H D Rahardjo, T Setyawardani and H Subagja

+ Open abstract  View article  PDF

OPEN ACCESS 032002

Analysis of SWOT Marketing Strategies and 7P Influence on Purchasing Decision

A Komari, L D Indrasari, A Y Tripariyanto and S Rahayuningsih

+ Open abstract  View article  PDF

OPEN ACCESS 032003

Bioeconomic two predator-prey model of harvesting fishery

S M Belwawin, M Riyana and D Harmawati

+ Open abstract  View article  PDF

OPEN ACCESS 032004

Analysis of Smartphone Users Movement Using Data Mining Methods and SWOT Analysis in East Surabaya Areas

Sumiati, A N Saloh and Purwati

+ Open abstract  View article  PDF

OPEN ACCESS 032005

Inventory Control System Using Distribution Requirement Planning (DRP) (Case Study, Food Company) Cookies policy.



[+ Open abstract](#) [View article](#) [PDF](#)

OPEN ACCESS

032006

Green Supply Chain Operation Reference (Green SCOR) Performance Evaluation (Case Study: Steel Company)

F Pulansari and A Putri

[+ Open abstract](#) [View article](#) [PDF](#)

OPEN ACCESS

032007

Redesign of The Production Facility Layout by Using Systematic Layout Planning Method at Cahaya Bintang Mas Company Surabaya

Sunardi, J Ananda Esya and Budi Santoso

[+ Open abstract](#) [View article](#) [PDF](#)

OPEN ACCESS

032008

Determination of Maintenance Schedule of Loading and Unloading Pump Machine Using Genetic Algorithm Method

Dwi Sukma Donoriyanto, Ika Yuniar Silfiana, W Endang Pudji, Akmal Suryadi and L. Urip Widodo

[+ Open abstract](#) [View article](#) [PDF](#)

OPEN ACCESS

032009

The Ergonomic Shooting Net Design for Pond Farmers

Tranggono, Rusindiyanto and Moch. Ali

[+ Open abstract](#) [View article](#) [PDF](#)

OPEN ACCESS

032010

Optimization of Pectin Extraction from Pedada Fruit (*Sonneratia caseolaris*)

Jariyah, Murtiningsih and A. Widyawati

[+ Open abstract](#) [View article](#) [PDF](#)

OPEN ACCESS

032011

Synthesis And Characterization Of Adsorbent From Solid Waste Of Ceramics Industry

Nove Kartika Erliyanti, Srie Muljani, Dimas Baskoro and Novia Wulan Erza Prastika

[+ Open abstract](#) [View article](#) [PDF](#)

OPEN ACCESS

032012

Layout Design in Group Technology Using Cellular Manufacturing System

D Ernawati, N Rahmawati, E Pudji, NK Sari and A Wianto

[+ Open abstract](#) [View article](#) [PDF](#)

This site uses cookies. By continuing to use this site you agree to our use of cookies. To find out more, see our Privacy and Cookies policy.



-
- OPEN ACCESS** 032013
Physicochemical And Sensory Properties Of Pedada Fruit (*Sonneratia caseolaris*) Bar
A Y T Putra, E K B Susiloningsih and M A Susanti
[+](#) Open abstract [View article](#) [PDF](#)
-
- OPEN ACCESS** 032014
Characterization of Soyghurt Synbiotic Drink From Soymilk and Purple Yam Extract
Rosida, E E Amalia and S Djajati
[+](#) Open abstract [View article](#) [PDF](#)
-
- OPEN ACCESS** 032015
Analysis of Quality Management by Implementing Total Quality Management Based on Deming Prize
Enny Aryanny and Iriani
[+](#) Open abstract [View article](#) [PDF](#)
-
- OPEN ACCESS** 032016
Husk as a Substitute for Styrofoam Plastic Products Manufacturing Packaging
Reda Rizal, Lomo Mula Tua and Sargi Br. Ginting
[+](#) Open abstract [View article](#) [PDF](#)
-
- OPEN ACCESS** 032017
Designing Passengers Cabin Of Carrier Vehicles Of 6x6 Armour Personnel With Principles Of Ergonomic
Halim Mahfud, Lilik Zulaihah, Rifa Arifati and Nurfajriah
[+](#) Open abstract [View article](#) [PDF](#)
-
- OPEN ACCESS** 032018
Integration of Quality Function Deployment and Analytical Hierarchy Process in Developing Digital Application Features
Akhmad Nihomuz Zaman, Arraz Naoval Viacenza, Alina Cynthia Dewi, Muhamad As'adi and Donny Montreano
[+](#) Open abstract [View article](#) [PDF](#)
-
- OPEN ACCESS** 032019
Comparation of Schedulling Methods: Campbell Dudek Smith, Palmer and Dannenbring to Minimize Makespan
I D Utami, I Kuswandi and D E Wibowo
[+](#) Open abstract [View article](#) [PDF](#)
-
- OPEN ACCESS** 032020
Biorheological Modelling How Much Pushing Operators' Moment of Force in Punching Process



Rullie Annisa

[+ Open abstract](#) [View article](#) [PDF](#)

OPEN ACCESS

032021

System-Dynamic Simulation Application on Farming Eco-Efficiency Measurement

W Findiastuti, M L Singgih and M Anityasari

[+ Open abstract](#) [View article](#) [PDF](#)

OPEN ACCESS

032022

Rework Reduction and Quality Cost Analysis of Furniture Production Processes Using the House of Risk (HOR)

Kukuh Winarso and Moh. Jufriyanto

[+ Open abstract](#) [View article](#) [PDF](#)

OPEN ACCESS

032023

Developing Digital Application to Improve Business Process Sustainability in An Indonesian Fast Moving Consumer Goods Company

I Cahyadi

[+ Open abstract](#) [View article](#) [PDF](#)

OPEN ACCESS

032024

Virtual Enterprise for Batik's Small Medium Enterprises

Trisita Novianti

[+ Open abstract](#) [View article](#) [PDF](#)

OPEN ACCESS

032025

Redefining Industry 4.0 and Its Enabling Technologies

Khamdi Mubarak

[+ Open abstract](#) [View article](#) [PDF](#)

OPEN ACCESS

032026

Design of the mBatik, textile hot wax applicator to emulate hand drawn batik using CNC plotter machine and characterization of wax plotting parameters

Sabarudin Akhmad, Anis Arendra, Mu'alim, Kukuh Winarso and Rachmad Hidayat

[+ Open abstract](#) [View article](#) [PDF](#)

OPEN ACCESS

032027

The Accuracy Measurement of Stock Price Numerical Prediction

Samsul Amar, Andi Sudiarso and Muhammad Kusumawan Herliansyah

[+ Open abstract](#) [View article](#) [PDF](#)

This site uses cookies. By continuing to use this site you agree to our use of cookies. To find out more, see our [Privacy and Cookies policy](#).



OPEN ACCESS

032028

Key Factors of Success Technology Transfer from Higher Education To Creative Industry in Bangkalan, Madura

Retno Indriartiningtias, W Andi Rahadiyan, Subagyo and Budi Hartono

[+ Open abstract](#) [View article](#) [PDF](#)

OPEN ACCESS

032029

Integration of Variable Acceptance Sampling and Maintenance Policy Based on Process Capability Index

S F Salimah and N Kurniatii

[+ Open abstract](#) [View article](#) [PDF](#)

OPEN ACCESS

032030

The Causality of Monosodium Glutamate Fourier Transform Infrared (FTIR) Absorbance Pattern with Wave Peaks from Several Seasoning Product (Savoury Flavors)

Mujianto, Wignyanto, S Kumalaningsih, Aulianni'am and Agriculture

[+ Open abstract](#) [View article](#) [PDF](#)

OPEN ACCESS

032031

Building a Smart and Intelligent Factory of the Future with Industry 4.0 Technologies

K Mubarok and EF Arriaga

[+ Open abstract](#) [View article](#) [PDF](#)

OPEN ACCESS

032032

Evaluation and Improvement of E-toll Card System at Suramadu Toll Gate

Rachmad Hidayat

[+ Open abstract](#) [View article](#) [PDF](#)

Mechanical Engineering

OPEN ACCESS

032033

Development of an Automatic Anti Pitching System (APS) Autonomous Surface Vehicle (ASV) for Fish Mapping

Noverdo Saputra, Muhammad Arifudin Lukmana and Purwo Joko Suranto

[+ Open abstract](#) [View article](#) [PDF](#)

OPEN ACCESS

032034

Photovoltaic driven adsorption-cooling cycle

I Gusti Agung Bagus Wirajati, I Nengah Ardita and I Gede Nyoman Suta Waisnawa

[+ Open abstract](#) [View article](#) [PDF](#)

This site uses cookies. By continuing to use this site you agree to our use of cookies. To find out more, see our [Privacy and Cookies policy](#).

OPEN ACCESS



[+ Open abstract](#) [View article](#) [PDF](#)

OPEN ACCESS

032043

Optimization of Machining Parameters for Surface-roughness and Precision in EDM Using Response Surface Method

R M Yusron and R M Bisono

[+ Open abstract](#) [View article](#) [PDF](#)

OPEN ACCESS

032044

Investigating pump cavitation based on audio sound signature recognition using artificial neural network

Anis Arendra, Sabarudin Akhmad, Kukuh Winarso and Herianto

[+ Open abstract](#) [View article](#) [PDF](#)

OPEN ACCESS

032045

Performance Test of A mixture of Polypropylene Plastic Fuel from Pyrolysis with Gasoline to Torque and engine Power

Aditya Wahyu Pratama and Winarko

[+ Open abstract](#) [View article](#) [PDF](#)

OPEN ACCESS

032046

Analysis of HOTS Type Multiple-choice Test Items on Learning Automotive Electrical Systems in SMK Dharma Bahari Surabaya

Soeryanto, I M Arsana, R S Hidayatullah and S R Ariyanto

[+ Open abstract](#) [View article](#) [PDF](#)

OPEN ACCESS

032047

Development of Learning Media Design Engineering Integrated with Machinery Element and Drawing Machine Based on Contextual Learning

Djoko Suwito, Agung Prijo Budijono, Yunus, Wahyu Dwi Kurniawan and Soeryanto

[+ Open abstract](#) [View article](#) [PDF](#)

OPEN ACCESS

032048

The Effect of Nanofluid Volume Fraction to The Rate of Heat Transfer Convection Nanofluid Water- Al_2O_3 on Shell and Tube Heat Exchanger

I M Arsana, D R Agista, A Ansori, D H Sutjahjo and M Effendy

[+ Open abstract](#) [View article](#) [PDF](#)

OPEN ACCESS

032049

Disc Brake Type of Braking System on Rear Shaft of Go-kart Daiho 7.5 HP

A Y Tripariyanto, L D Indrasari, S V Widodo, and A Komari

This site uses cookies. By continuing to use this site you agree to our use of cookies. To find out more,

[Open abstract](#) [View article](#) [PDF](#)



-
- OPEN ACCESS** 032050
Analysis Of Resistance Of Materials That Have Las Connection In St 37 Steels
Farid Sariman, Christian Wely Wullur, Cipto and Daniel Parennden
[+ Open abstract](#) [View article](#) [PDF](#)
-
- OPEN ACCESS** 032051
Analysis of Skid and Rolling Vehicle
Cipto, Daniel Parennden, Hariyanto and Rahap M Bako
[+ Open abstract](#) [View article](#) [PDF](#)
-
- OPEN ACCESS** 032052
Effect Variations And Types of Smaw Welding Electrodes on A36 Steel to Tensile Test
Klemens Alrin Rahangmetan, Christian Wely Wullur and Farid Sariman
[+ Open abstract](#) [View article](#) [PDF](#)
-
- OPEN ACCESS** 032053
Analysis performance of forced convection cooling using synthetic jets with wave variations (sine, square, and triangular)
Bintang Arya Putra, Damora Rhakasywi, M As'adi and Nur Cholis
[+ Open abstract](#) [View article](#) [PDF](#)
-
- OPEN ACCESS** 032054
Performance analysis of forced convection coolers using synthetic jets with variations in altitude from synthetic jets to heat sources
Muchammad Baihaqi Muslich, Damora Rhakasywi, M As'adi and Nur Cholis
[+ Open abstract](#) [View article](#) [PDF](#)
-
- OPEN ACCESS** 032055
Effect of Metal Inert Gas Welding Process Parameters to Tensile Strength on ST 37 Steel Sheet Joint
Hakam Muzakki, Teguh Prasetyo, M Syafi'ul Umam, Ida Lumintu and Dwi Hartanto
[+ Open abstract](#) [View article](#) [PDF](#)
-
- OPEN ACCESS** 032056
The Effect Of The Submerged Arc Welding Parameters To Distortion On The Steel Joints
Emon Rifai and Hidayat
[+ Open abstract](#) [View article](#) [PDF](#)
-
- OPEN ACCESS** 032057
Friction and Wear Analysis of UHMWPE Material Using Pin-on-Disc Tester with
~~Lubricants and Non-Lubricants~~
M Wahyudi, R Ismail and J Jamar
[+ Open abstract](#) [View article](#) [PDF](#)
-



[+ Open abstract](#) [View article](#) [PDF](#)

OPEN ACCESS 032058

Addition Combustion Air Effect to Engine Performance K15-901 Using Bioethanol Fuel

Ibnu Irawan and Hairil Budiarto

[+ Open abstract](#) [View article](#) [PDF](#)

OPEN ACCESS 032059

Optimization of Metal Inert Gas Welding with Taguchi Method

Teguh Prasetyo, Hakam Muzakki, Ida Lumintu and Dwi Hartanto

[+ Open abstract](#) [View article](#) [PDF](#)

OPEN ACCESS 032060

Pre-processing for vibration signals features extraction and selection in real time investigating of CNC tool wear

Anis Arendra and Herianto

[+ Open abstract](#) [View article](#) [PDF](#)

Biomedical Engineering

OPEN ACCESS 032061

Medical Spirometer for Diagnosing COPD Base On The Measurement of FVC and FEV₁

Kemalasari, Debby Triany Fajar, Paulus Susetyo Wardana and Budi Nur Iman

[+ Open abstract](#) [View article](#) [PDF](#)

OPEN ACCESS 032062

The Implementation of Bilateral Control Symmetrical Position, Force Reflection and Feedback Force on the Haptic Manipulator

Sustin Farlinda, Vita Permatasari and Ahmad Fahriannur

[+ Open abstract](#) [View article](#) [PDF](#)

OPEN ACCESS 032063

The Effect of Ginger Extract (*zingiber officinale roscoe*) on the Number of Neutrophil Cells, Fibroblast and Epithelialization on Incision Wound

K I N Rahayu, I P S Suharto, A N Etika and S E Nurseskasatmata

[+ Open abstract](#) [View article](#) [PDF](#)

OPEN ACCESS 032064

Profile of Antibiotic Use and Germ Map in Pneumonia Patients in Pulmonary Space (Case Study at RSUD dr. Iskak. Tulungagung)

This site uses cookies. By continuing to use this site you agree to our use of cookies. To find out more, see our Privacy and Cookies policy.



[+ Open abstract](#) [View article](#) [PDF](#)

OPEN ACCESS

032065

Mefenamic acid treatment to ward follicles development and progesterone level

S Aminah, D Lutfiasari, D K Prasetyanti and M E Fitriasnani

[+ Open abstract](#) [View article](#) [PDF](#)

OPEN ACCESS

032066

The Correlation between CD4 Count Cell and Opportunistic Infection among HIV/AIDS Patients

I Jayani, Susmiati, EWinarti and W Sulistyawati

[+ Open abstract](#) [View article](#) [PDF](#)

Electrical Engineering & Electronics

OPEN ACCESS

032067

Translational Motion Estimation Using Kinect

Muhammad Fuad

[+ Open abstract](#) [View article](#) [PDF](#)

OPEN ACCESS

032068

Designing a Diabetes Mellitus Detection Tool Using the Backpropagation Method

R Alfita, D Rahmawati, R V Nahari and D Iskandar

[+ Open abstract](#) [View article](#) [PDF](#)

OPEN ACCESS

032069

Misty Image Repair System with Dark Channel Prior and CLAHE

K Joni, R Alfita and H A Dewi

[+ Open abstract](#) [View article](#) [PDF](#)

OPEN ACCESS

032070

Detecting Text in the Scene Text Image Using Fast Fourier Transform

R V Nahari, S S Putro, N Setiawan and R Alfita

[+ Open abstract](#) [View article](#) [PDF](#)

OPEN ACCESS

032071

Digital Filter Design for Classifying Coconut Ages using Blackman FIR and Elliptic IIR Filters

Diana Rahmawati, Haryanto, Fahrus Sakariya and Heri Setiawan

[+ Open abstract](#) [View article](#) [PDF](#)

This site uses cookies. By continuing to use this site you agree to our use of cookies. To find out more, see our Privacy and Cookies policy.



OPEN ACCESS 032072

Content Based Image Retrieval Using Two Color Feature Extraction

F A Mufarroha, D R Anamisa and A G Hapsani

[+](#) Open abstract [View article](#) [PDF](#)

OPEN ACCESS 032073

Comparison of Automatic Water Taps Using Ultrasonic Sensors and PIR Sensors

Vivi Tri Widyaningrum

[+](#) Open abstract [View article](#) [PDF](#)

OPEN ACCESS 032074

Monitoring And Control Web Based System For Peanut At The Green House

Sri Wahyuni and Ratna Himatul Khusnia

[+](#) Open abstract [View article](#) [PDF](#)

OPEN ACCESS 032075

Magnetic Braking System Using Electromagnetic Force

Budiarto Hairil

[+](#) Open abstract [View article](#) [PDF](#)

OPEN ACCESS 032076

Prototype Design Of Automatic Anchovy Drying Robot Using Arduino ATmega 2560

M Pramudia, A Salim and T Prasetyo

[+](#) Open abstract [View article](#) [PDF](#)

OPEN ACCESS 032077

Hijaiyah Letters Sign Language Recognition for Deaf and Hearing Impaired Children Based on Principal Component Analysis Method

I Achmad Fiqhi, R Diana and I Wita

[+](#) Open abstract [View article](#) [PDF](#)

OPEN ACCESS 032078

Identification of Disease Types on Tea – Plant Varieties Based Image Processing With K-Nearest Neighbor Method

Adi Kurniawan Saputro, Kunto Aji Wibisono and Faidhdatus Puji Pratiwi

[+](#) Open abstract [View article](#) [PDF](#)

OPEN ACCESS 032079

Smart Helmet Control System Using Heart Pulse Indicator

Faikul Umam, Hairil Budiarto and Ach. Dafid

This site uses cookies. By continuing to use this site you agree to our use of cookies. To find out more,

[+](#) Open abstract [View article](#) [PDF](#)

See our [Privacy and Cookies policy](#).



-
- OPEN ACCESS** 032080
Planning of Path Loss in Large Scale Signal Propagation Model at 5G Network by Using Linear Regression Methods
A Ubaidillah, M Ulum and S. Pramono
[+](#) [Open abstract](#) [View article](#) [PDF](#)
-
- OPEN ACCESS** 032081
Signal Classification and Electromyography (EMG) Instrumentation Design as Basic Electronic Control System
Miftachul Ulum, Fatkur Rozi and Achmad Fiqhi Ibadillah
[+](#) [Open abstract](#) [View article](#) [PDF](#)
-
- OPEN ACCESS** 032082
Money Authenticity Detector Design Using Artificial Neural Network Method for Blinds
W Kunto Aji, Miftachul Ulum and Aslih Nur' Afifah
[+](#) [Open abstract](#) [View article](#) [PDF](#)
-
- OPEN ACCESS** 032083
Performance of 2.4 GHz Xbee for Digital Image Transmission with Yagi Antenna
Haryanto, K Rohman, D Rahmawati and L Anifah
[+](#) [Open abstract](#) [View article](#) [PDF](#)
-
- OPEN ACCESS** 032084
Leader-Follower Formation Tracking Of Multiple Mobile Robots With Constant Leader Velocity
M. Latif
[+](#) [Open abstract](#) [View article](#) [PDF](#)
-
- OPEN ACCESS** 032085
Optical Spectrum of Uncladded Fiber Bragg Grating for Glucose Concentration Measurement
Nur Abdillah Siddiq, Asnawi Asnawi, Sib Krishna Goshals and Yono Hadi Pramono
[+](#) [Open abstract](#) [View article](#) [PDF](#)
-
- OPEN ACCESS** 032086
Comparison of Partial Discharge Characteristics Detected by RC Detector and Rectangular Antenna
Deni Tri Laksono, Dedi Tri Laksono and Umar Khayam
[+](#) [Open abstract](#) [View article](#) [PDF](#)
-
- OPEN ACCESS** 032087
Automatic Clean Water Treatment System Using The Sugeno Fuzzy Method
[+](#) [Open abstract](#) [View article](#) [PDF](#)
-
- This site uses cookies. By continuing to use this site you agree to our use of cookies. To find out more, [click here](#)

[+ Open abstract](#) [View article](#) [PDF](#)

OPEN ACCESS

032088

Smart Stick For the Blind Using Arduino

A S Romadhon and A K Husein

[+ Open abstract](#) [View article](#) [PDF](#)

OPEN ACCESS

032089

Comparative Measurement of Partial Discharge Using Spiral Antenna with RC Detector on High Voltage Equipment

Dedi Tri Laksono, Deni Tri Laksono and Umar Khayam

[+ Open abstract](#) [View article](#) [PDF](#)

OPEN ACCESS

032090

Design and Control a High Gain Synchronous Buck Converter for a Solid State Distribution Transformer

I N W Satiawan, I B F Citarsa and I M B Suksmadana

[+ Open abstract](#) [View article](#) [PDF](#)

OPEN ACCESS

032091

Implementation of Nighttime Radiance Threshold Class for Green Zone Energy Mapping

I Ketut Swardika, Putri Alit Widyastuti Santiary and I Gede Hendrawan

[+ Open abstract](#) [View article](#) [PDF](#)

OPEN ACCESS

032092

Data Structure Comparison Between MySql Relational Database and Firebase Database NoSql on Mobile Based Tourist Tracking Application

I K G Sudiarta, I N E Indrayana, I W Suasnawa, S A Asri and Putu Wijaya Sunu

[+ Open abstract](#) [View article](#) [PDF](#)

OPEN ACCESS

032093

Design of Children Monitoring Application for Outdoor Activities Using a Smart Watch

I N E Indrayana, Putu Sutawinaya, N M Wirasyanti, I Ketut Swardika and Putu Wijaya Sunu

[+ Open abstract](#) [View article](#) [PDF](#)

OPEN ACCESS

032094

Implementation of Prototyping Method on Smart Village Application

S A Asri, I N G A Astawa, I G A M Sunaya, K A Yasa, I N E Indrayana and W Setiawan

[+ Open abstract](#) [View article](#) [PDF](#)



-
- OPEN ACCESS** 032095
Adaptive Genetic Algorithm for High School Time-Table
N G A P H Saptarini, P I Ciptayani, N W Wisswani and I W Suasnawa
[+](#) Open abstract [View article](#) [PDF](#)
-
- OPEN ACCESS** 032096
Quadcopter Surveyor Drone Wind Velocity Data Characteristic for Optimal Hotwire Sensor Position
Bayu Rudiyanto, Budi Hariono and Azamataufiq Budiprasojo
[+](#) Open abstract [View article](#) [PDF](#)
-
- OPEN ACCESS** 032097
Design of function generator using arduino due 12 bit dac
F Baskoro, E Sulistiyo, I Basuki, A Widodo and A P Nurdiansyah
[+](#) Open abstract [View article](#) [PDF](#)
-
- OPEN ACCESS** 032098
Development of Programming Ability Test Application For Informatics Students
S R Nurdin, IGPE Prisma, D R Prehanto and IKD Nuryana
[+](#) Open abstract [View article](#) [PDF](#)
-
- OPEN ACCESS** 032099
The effect of the implementation of project based learning on learning activities of electrical engineering students
S I Haryudo, A I Agung, R Firmansyah, W A Wibowo, Ekohariadi and Munoto
[+](#) Open abstract [View article](#) [PDF](#)
-
- OPEN ACCESS** 032100
Industrial Monitoring and Controlling System on Pressure Machines Using Internet of Thing (IoT)
L Anifah, M R Rahmadian, R Firmansyah and M S Zuhrie
[+](#) Open abstract [View article](#) [PDF](#)
-
- OPEN ACCESS** 032101
Design PV Standalone System in Electrical Engineering Laboratory of Musamus University Using PVSyst 6.7.0 PRO30
Frederik Haryanto Sumbung, Paulus Mengera and Damis Hardiantono
[+](#) Open abstract [View article](#) [PDF](#)
-
- OPEN ACCESS** 032102
Design of Yagi-Uda Antenna for GSM-A Modules at 800 MHz
Adik Putra Andika, Vinsensius Letsoin, Rapha Nichita Kaikatui, Paulus Mangera and Damis Hardiantono



[+ Open abstract](#)

 [View article](#)

 [PDF](#)

JOURNAL LINKS

[Journal home](#)

[Journal Scope](#)

[Information for organizers](#)

[Information for authors](#)

[Contact us](#)

[Reprint services from Curran Associates](#)





Source details

Journal of Physics: Conference Series

Scopus coverage years: from 2005 to Present

ISSN: 1742-6588 E-ISSN: 1742-6596

Subject area: Physics and Astronomy: General Physics and Astronomy

Source type: Conference Proceeding

CiteScore 2021

0.8



SJR 2021

0.210



SNIP 2021

0.395



[View all documents >](#)

[Set document alert](#)

[Save to source list](#) [Source Homepage](#)

[CiteScore](#) [CiteScore rank & trend](#) [Scopus content coverage](#)

i Improved CiteScore methodology



CiteScore 2021 counts the citations received in 2018-2021 to articles, reviews, conference papers, book chapters and data papers published in 2018-2021, and divides this by the number of publications published in 2018-2021. [Learn more >](#)

CiteScore 2021 ▼

$$0.8 = \frac{74,925 \text{ Citations } 2018 - 2021}{96,702 \text{ Documents } 2018 - 2021}$$

Calculated on 05 May, 2022

CiteScoreTracker 2022 ⓘ

$$0.9 = \frac{90,075 \text{ Citations to date}}{95,457 \text{ Documents to date}}$$

Last updated on 05 April, 2023 • Updated monthly

CiteScore rank 2021 ⓘ

Category	Rank	Percentile
Physics and Astronomy		
General Physics and Astronomy	#195/240	18th

[View CiteScore methodology >](#) [CiteScore FAQ >](#) [Add CiteScore to your site](#)

About Scopus

[What is Scopus](#)

[Content coverage](#)

[Scopus blog](#)

[Scopus API](#)

[Privacy matters](#)

Language

[日本語版を表示する](#)

[查看简体中文版本](#)

[查看繁體中文版本](#)

[Просмотр версии на русском языке](#)

Customer Service

[Help](#)

[Tutorials](#)

[Contact us](#)

ELSEVIER

[Terms and conditions ↗](#) [Privacy policy ↗](#)

Copyright © Elsevier B.V. ↗. All rights reserved. Scopus® is a registered trademark of Elsevier B.V.

We use cookies to help provide and enhance our service and tailor content. By continuing, you agree to the use of cookies ↗.



PAPER • OPEN ACCESS

Design and Control a High Gain Synchronous Buck Converter for a Solid State Distribution Transformer

To cite this article: I N W Satiawan *et al* 2020 *J. Phys.: Conf. Ser.* **1569** 032090

View the [article online](#) for updates and enhancements.



IOP | ebooks™

Bringing together innovative digital publishing with leading authors from the global scientific community.

Start exploring the collection—download the first chapter of every title for free.

Design and Control a High Gain Synchronous Buck Converter for a Solid State Distribution Transformer

I N W Satiawan¹ I B F Citarsa¹ I M B Suksmadana¹

¹Electrical Department, Engineering Faculty, University of Mataram
nwahyus@unram.ac.id

Abstract. A Conventional distribution transformer consists of bulky windings, cores and coolant liquid hence it is weighty and large in size. Now days, supporting by development of power semiconductor devices, the idea to develop distribution transformers using switching power converter technology becomes viable. This paper proposed a new structure of a solid state transformer (SST) for power electrical distribution system. The proposed SST works without utilizes high frequency isolating transformer. Instead, high gain cascaded Buck converters are used. The design of Buck Converters involves calculation of the applied components such as Inductors and Capacitors. Simulation result verifies that Buck Converters work well to reduce DC voltage of 25 kV DC voltage to 620 V DC without excessive ripple. The proposed SST is successfully operated to step down 20 KV of AC voltage to 400 V with THD of output voltage less than 2 %.

1. Introduction

Transformers take a very important role in power electrical system. Distribution (transmission) lines operate in high voltage system to reduce the current flow in the conductor hence reduces the voltage drop as well as power losses in the system. Transmission lines work at 500 kV or 150 kV and then stepped down to 20 kV in the distribution line. In the load side the 20 kV voltage is reduced to 220/380 V for the safety reason. Reliability of power electrical system is fully depended on the existence of transformers. Conventional transformers involve bulky winding, cores, and liquid as a coolant. As a consequent, the size of transformers is large, heavy and the lubricant waste causes bad effect to environment.

Recently, supporting by a rapid development in the solid state technology, conventional distribution transformers have been proposed to be replaced by power electronics devices that leads to solid state transformer (SST). Unlike conventional transformers that work based on electromagnetic induction principle, SST operates based on switching power electronic converter technology. Advantages of SST over conventional transformer are compact in size, significant reduction in weight, environmentally friendly and flexibility in power factor control using closed loop control [1,2]. SST has been successfully applied in many applications namely Railway Traction, Smart Grid, Power Quality Improvement[3-5]. Recently, SST is also applied in Power Distribution System. [6-8]

The first structure of SS-trafo has been initiated in 1980 by Navi Researchers [9]. The structure was then improved by EPRI Corp..in 1995 [10]. The common topology of SST consists of power electronic converter and high frequency transformer as is shown in Figure 1. In high frequency operation, the size of conductors is significantly reduced hence reduce the dimension of the transformer. It is clearly shown in Figure 1 that, operation of SST involves of three main stages i.e rectification stage that converts high AC voltage to high DC voltage, DC to DC stage that converts high voltage DC to low voltage DC and inverter stage that converts the low DC voltage into low AC voltage in the load side. In particular, the DC to DC stage involves DC to AC part (Inverter), high frequency transformer and AC to DC part (rectifier).[11,12] One drawback of the SST with high



frequency transformer is that the efficiency system can be reduced since a high frequency operation increases transformer losses especially core losses and conductor skin effect.

In order to solve the problem, a new structure of SST is proposed. The proposed SST replaces the high frequency transformer with cascaded DC to DC converter as shown in Figure 2. This paper proposed design and control of cascaded high gain Buck Converters for a power distribution system. The design is emphasized in the calculation of the involved components in the Buck Converters, as well as controlling Buck Converters to step down the DC voltage of 20 kV into 600 V. The proposed SST is designed to convert a AC voltage input of 20 kV to 220/400 V in the secondary side with acceptable voltage quality (THD less than 5%).

2. Design of Solid State Transformer

It has been mentioned in the previous section that the proposed SS transformer utilizes high gain DC to DC Converters instead of uses a high frequency transformer as shown in the Figure 2. Here, the DC to DC converter operates to step down a 25 kV DC voltage to 600 V DC voltage. Subsequently, a 600 V DC is used as an input for a three-phase inverter to achieve a 400 V line to line voltage or 220 V phase to neutral voltage

A common Buck Converter applied one power switch and one diode. In high voltage and high current operation, it is preferable to replace the diode with a power switch that leads to a Synchronous Buck Converter. Using Synchronous Buck Converter is advantageous because the efficiency is improved and higher power rating [13]. The two switches operate in complementary manner hence two pulse signals with opposite pattern are required to control the two switches. In order to achieve high power gain of DC to DC converter, three Buck Converters are arranged in series connection or known as cascaded Buck Converter as is shown in Figure 3. Cascaded structure has been applied in some application for Boost Converter as presented in the literatures [14]

Output voltage of Buck Converter is governed by duty cycle according to equation (1) In order to achieve output with acceptable ripple, the value of Inductor and Capacitor have to be calculated using equations (2) and (3). [15]. In this design, the Buck Converters are controlled by using MOSFET with frequency switching of 20 k Hz, duty cyce of 20% for the all Buck Converters, expected ripple less than 5% the minimum value of Inductors (L) and Capacitors (C) are $2.5 \text{ e}^{-3} \text{ H}$ and $8 \text{ e}^{-6} \text{ F}$ respectively.

$$V_{dc} = DV_{in} \dots\dots\dots (1)$$

$$L_{\min} = \frac{(1 - D_{\min})R_{\max}}{2 \cdot f_s} \dots\dots\dots (2)$$

$$C_{\min} = \frac{(1 - D_{\min})R_{\max}}{8L \cdot f_s^2 \left(\frac{\Delta V_o}{V_s}\right)} \dots\dots\dots (3)$$

where, D is duty cycle, f_s is frequency switching of power switches, R is resistance load and $\Delta V_o/V_s$ is the desired ripple of the output voltage

3. Results and Discussion

The proposed SST is verified using Simulink Matlab. The power semiconductor swithes are modelled using Sim PowerBlockSet. Buck Converters utilize IGBTs and Inverter uses MOSFETs. The complete parameter of Buck Converters including the specification of IGBT is presented in Table 1.

The proposed SST utilises 6 switches full wave rectifier to achieve full wave rectification. In simulation, Rectifier utilizes Thyristors instead of Diodes in order to achieve higher power rating of component. Input output waveforms of rectifier are shown in Figure 4. It is depicted that rectifier converts 20 kV line to line rms voltage to 25,3 kV DC voltage. The result is match with expectation since in a full wave rectification. Further, the performance of Buck Converter is discussed. DC to DC converter takes a very important role to achieve high range of DC voltage conversion i.e reduce the 23 kV DC voltage to 600 V. The DC to DC conversion operates simultaneously in three steps as presented in Figure 4.

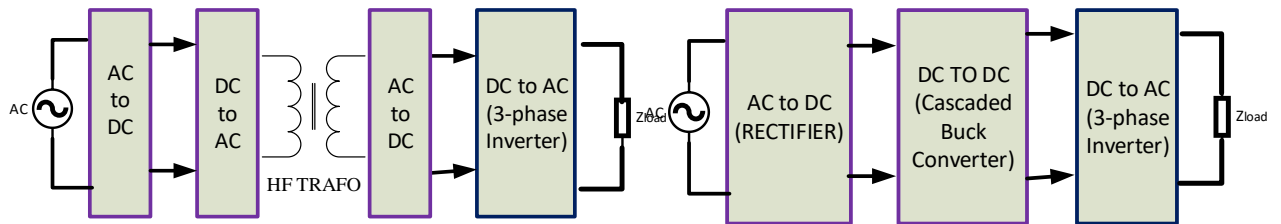

Figure 1. Common topology of SST.

Figure 2. Proposed Solid State Transformer

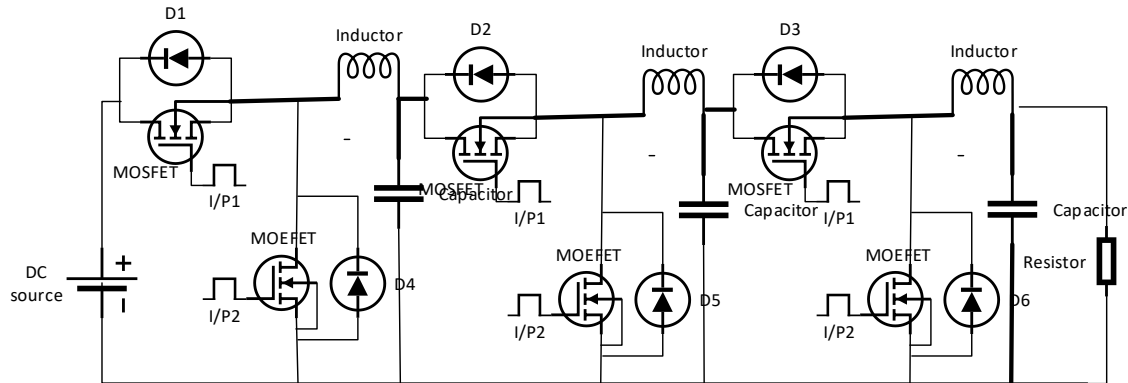

Figure 3. Cascaded Asynchronous Buck Converter Circuit

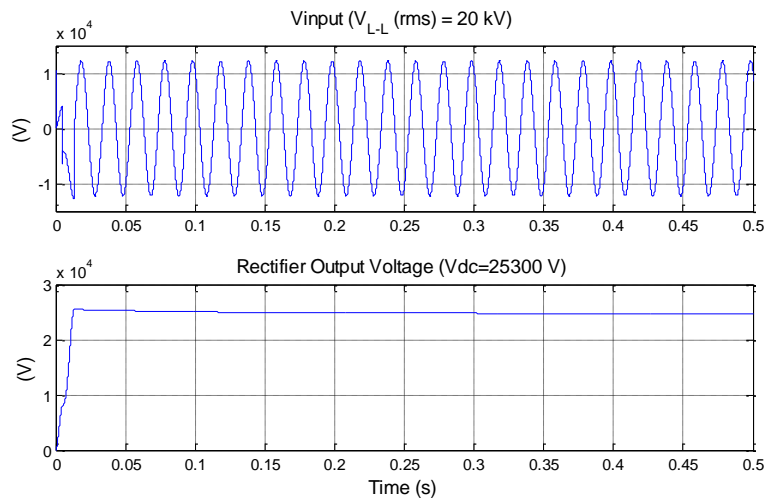

Figure 4. Rectifier input – output voltage waveforms

Table 1. Parameter simulation of DC to DC converter

Component	Symbol	Value
Switches	IGBT	
Snuber resistance	R_s	1e5 Ohm
Resistance	R_{on}	0.01 Ohm
Inductor	L	2.5 e-3 H
Capacitor	C	8 e-6 F
Frek. switching	F_s	20.000 Hz
Duty Cycle	D	20%

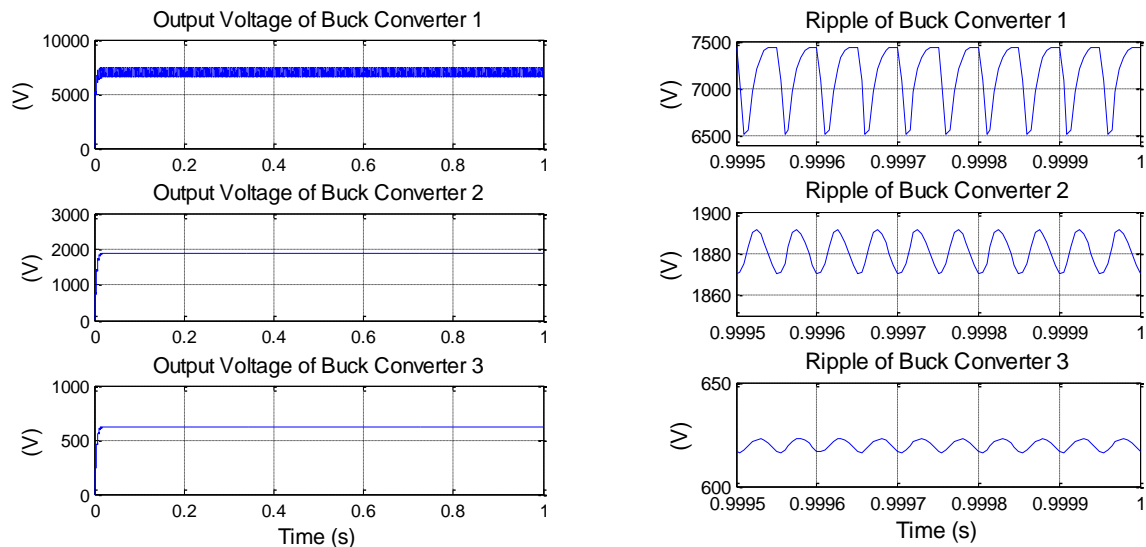

Figure 5. Output voltage of Buck Converters (a) and the respective ripple (b)

It is revealed in Figure 5 that gradual reduction of DC voltage is achieved from 23 kV to 8.000 V and then subsequently 8000 V reduces to 1900 V and finally, 1900 V reduces to target DC voltage of 600 V. The DC output voltages are matches with expectation since Buck Converters operate using 20% duty cycle (d). The final DC output 600 V DC voltage contains less than 5% ripple with respect of the target voltage as shown in Figure 5 (b). This result indicates that selection of used components (L and C) has been properly designed. Improper values of L and C causes excessive ripples that potentially causes distorted SST output voltage. Figure 6 shows the DC voltage output ripple for various values of L and C . Giving L and C lower than the designed value causes significant ripple in the output (Figure 5a). On the other hand, giving the higher values of L and C , it may reduce the ripple but effect to the cost and availability of the component in market (Figure 5b).

The 600 V DC voltage is then use as an input of inverter. The three phase inverter utilizes six IGBT power switches. The switches are controlled using sinusoidal PWM technique with frequency switching of 2 kHz to achieve 400 V rms line to line output voltage. Figure 7 shows the unfiltered and filtered line-to-line output voltage waveform of inverter and the harmonics spectra. It is clear that the unfiltered voltage contains free low-order harmonics. The low-order harmonics are shifted into around multiple switching frequency and its side band. Moreover, Figure 7 (b) depicts that sinusoidal output voltage has been achieved by applying a proper filter. It is witnessed in the spectrum that fundamental component of output voltage contains of about 400 V (rms) line-to line voltage. Voltage waveform is free from harmonics content hence THD reduce from 68.8% to 1.081%.

Finally, the whole input-output voltage waveform of the proposed SST is presented in Figure 8. It is clearly shown that the 20 kV AC voltage has been successfully step down into 420 V of output voltage with THD less than 2 %. This result indicates that the distribution transformer can be realized using switching power conversion concept without using any windings transformer that works using voltage induction principle. It is however, the only drawback of SST is that the load current can be badly distorted due to the applied power semiconductor devices with high switching frequency..

4. Conclusion

This paper proposed a new solid state distribution transformer. Instead of using high frequency transformer, high gain of Buck Converters is applied. In order to achieve of high range of voltage reduction, three Buck converters are operated in cascaded. The proposed SST is verified using Matlab/Simulink. Simulation result shows that the cascaded Buck Converters work well to reduce 25 kV DC into 620 V DC with DC voltage ripple less than 5 %. It is also shown that the inverter part also shows a good performance to reach the expected voltage output of 400 V with THD less than 1.5%.

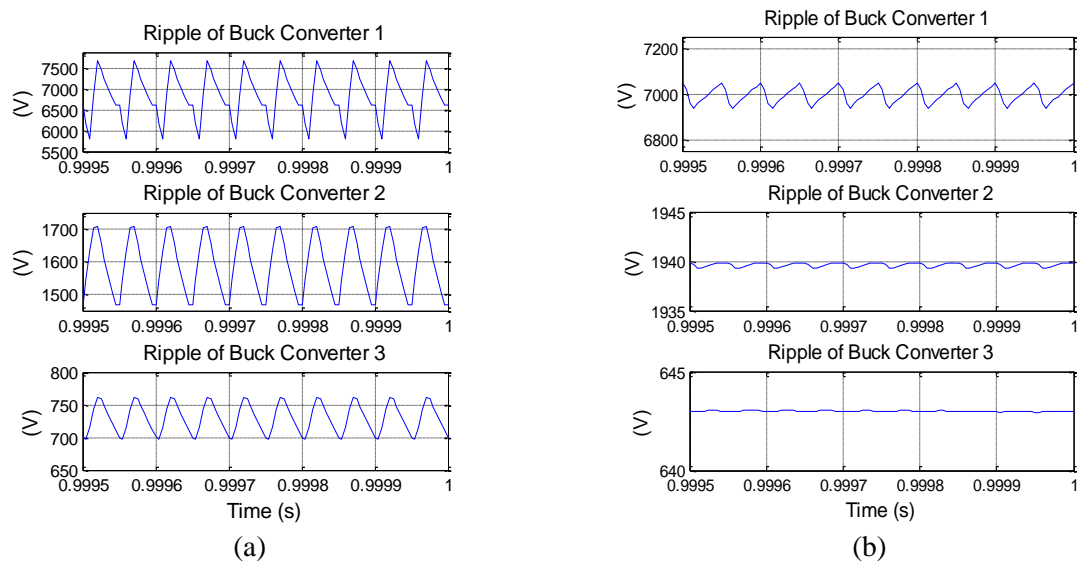

Figure 6. Output voltage ripple of Buck Converters for various values of Inductor and Capacitor

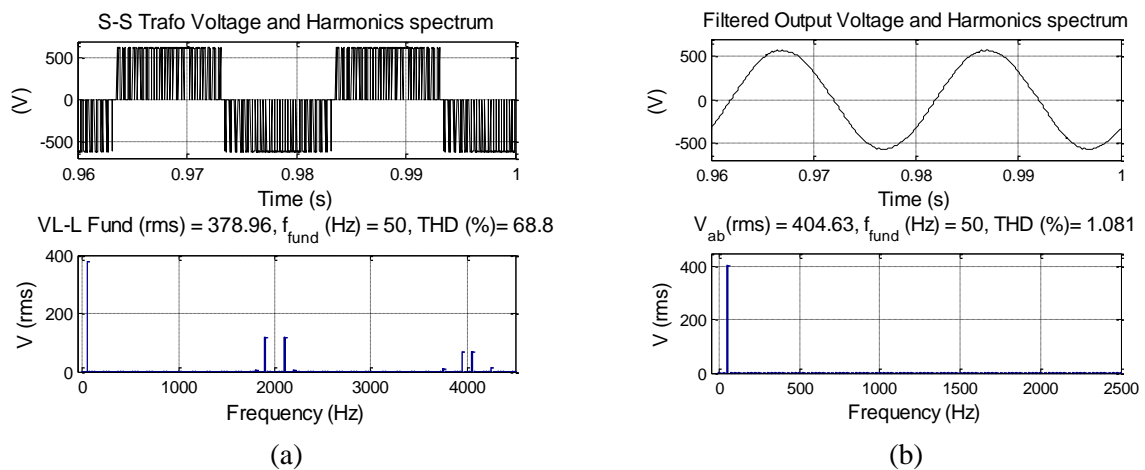

Figure 7. Unfiltered (a) and filtered inverter's output voltage (b)

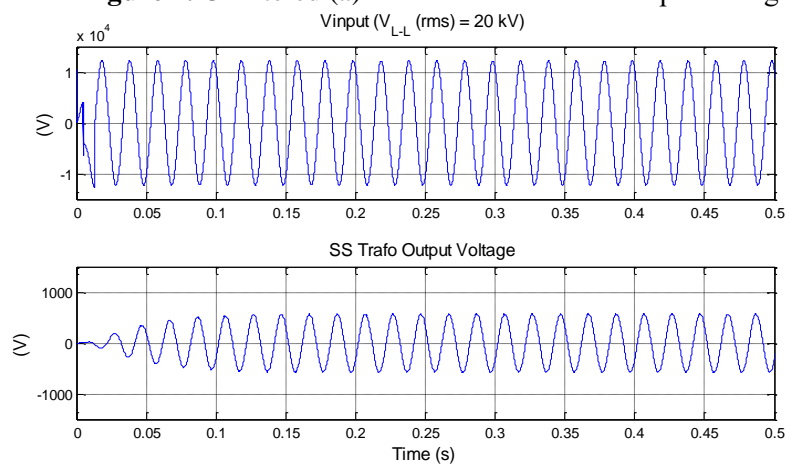

Figure 8. Input and final output of the proposed SS Transformer

In general, it is proven that the proposed SST has been successfully developed to convert a 20 kV AC voltage to 400 V rms line to line voltage. The only thing that needs to be further considered in realizing the proposed SST is that the highly distorted load current may happen due to the use of high frequency switching of power semiconductor devices.

Acknowledgment

My sincere gratitude and appreciation goes to Directorate Research and Community Service (DRPM), Ministry of Higher Educations Republic of Indonesia for the funding and all of supported material hence the paper can be realised.

References

- [1] Rathod D K 2014, Solid state Transformers (SST) Review of Recent development *Advance in Electronic and Electric Engineering* Vol.4 No.1 pp.45-50
- [2] Ahmed, K.Y., Yahaya, N.Z., Asirvadam, V.S., dan Ibrahim, O, (2015), Modeling and Simulation of Power Electronic Distribution Transformer Based on a Three Level Converter, *Applied Mechanics and materials*, Vol.785, pp. 151 -155
- [3] Aceiton R, Weber J, Bernet S 2018 Input Filter for a Power Electronics Transformer in a Railway Traction Application *IEEE Transactions on Industrial Electronics* Vol. 65, No. 12,
- [4] Ardeshir J F, Ajami A, Jalilvand A, Mohammadpour A, Flexible Power Electronic Transformer for Power Flow Control Applications *Journal of Operation and Automation in Power Eng*, Vol. 1, No. 2, pp. 147 – 155
- [5] Ramki P, and Muniraj C 2015 Design a Power Electronic Transformer for Micro Grid Applications *Int.l Journal of Advances in Electrical and Electronics Eng*, vol. 3 no. 1 pp.08 – 17
- [6] Duan, Q., Wang, J., Ma, C., Gu, B., Ji, B., Qiu, P., You, J., 2015 Flexible power distribution unit — A novel power electronic transformer development and demonstration for distribution sistem, *Proc. IEEE 41s Annual Industrial Electronics Society Conf. IECON15 Yokohama* , 9 -2 Nov. 2015
- [7] Montoya, R.J.G., 2015 High-Frequency Transformer Design for Solid State Transformers in Electric Power Distribution Systems, *PhD Thesis*, University of Arkansas, Fayetteville.
- [8] Ronan, E.R, Sudhoff, S.D., Glover, F., dan Galloway, D.L.2002 A power electronic-based distribution transformer *IEEE Trans. Power Delivery.*, vol.17, pp. 537 – 543.
- [9] Brooks, J.I., 1980 Solid state transformer concept development, *in Naval Material Command*, Port Hueneme, CA: Civil Eng. Lab., Naval Construction Battalion Centre.
- [10] EPRI Report, 1995, Proof of the principle of the solid-state transformer and the ac-ac switch mode regulator, *San Jose State Univ.*, San Jose, CA, EPRI TR-105067.
- [11] Li, L., dan Chen, D., 2003 Phase-shifted controlled forward mode AC/AC converters with high frequency AC links, *in proc. IEEE PEDS conference.*, vol.1, pp. 172 - 177, Nov. 2003.
- [12] Peng, F.Z., Chen, L., dan Zhang, F., (2003), Simple topologies of PWM AC-AC converters, *IEEE Letters. Power Electronics.*, vol.1, pp. 10 – 13. March 2003.
- [13] Lindiya A, Palani S, Iyyappan A, 2012 Performance Comparison of Various Controllers for DC-DC Synchronous Buck Converter, *Procedia Engineering* Vol 38, pp 2679-2693
- [14] Malik M Z, Ali A, Kumar D, 2017 A Two Cascaded Boost Converter with High Voltage Gain Module *International Journal of Computer Electrical Engineering* Vol. 9 No.2. pp. 476 -483
- [15] Muhamad, N D, Sahid M R, Yatim A H M, Idris N R N, Ayob M S 2005 Design of Power Stage and Controller for DC-DC Converter Systems Using PSPICE, *Proc. IEEE Power Electronics and Drive System*, Kuala Lumpur, 2015