



Reviewer's Guide

PART A: *Editorial Office Only*

SECTION I

Reviewer's Name:	Teti Zubaidah
E-Mail:	
Manuscript Number:	IJTech-G204
Title:	Performance comparison of PWM schemes of dual-inverter fed five-phase motor drives

PART B: *Reviewer Only*

SECTION II: Comments per Section of Manuscript

General comment:	This paper studies the performance of three different PWM schemes of dual-inverter by comparing THDVs when they fed five-phase motor drives. It is a quite well organized paper, which provides good results
Introduction:	Please use formats of title and authors as desired format in the template, since your paper will appear together with other papers
Methodology:	Clear
Results:	It may useful to state the results quantitatively in the abstract, rather than just qualitative.
Discussion:	Please revise the numbering order of the sections, e.g. there are two of Section II and two of Section IV.
Bibliography/References:	The references should be used in sequential numbering order. Please notice that ref [21] has never been used.
Others:	Still have to improve the English quality ...

SECTION III - Please rate the following: (1 = Poor) (2 = Fair) (3 = Average) (4 = Above Average) (5 = Excellent)

Originality:	3
Technical Quality:	3
Methodology :	3
Readability :	4
Practicability:	3
Organization:	4
Importance:	3

SECTION IV - Recommendation: (Kindly Mark with an X)

Accept As Is:	
Requires Moderate Revision:	Must to revise
Reject On Grounds of (Please Be Specific):	

SECTION V: Additional Comments

Please add additional comments, if any:

RETURN OF COMMENTS

Thank you for contributing to International Journal of Technology by completing this review. Please return your comments to:

Dr. Nyoman Suwartha
 Managing Editor
 International Journal of Technology (IJTech)
 Faculty of Engineering
 Universitas Indonesia,
 Kampus UI Depok 16424
 T: +62 (0) 21 78849052
 F: +62 (0) 21 7863506
 E: ijtech@eng.ui.ac.id atau ijtech.eng.ui@gmail.com

PERFORMANCE COMPARISON OF PWM SCHEMES OF DUAL-INVERTER FED FIVE-PHASE MOTOR DRIVES

**I Nyoman Wahyu Satiawan,
Ida Bagus Fery Citarsa, I Ketut Wiryajati**
Electrical Department, Faculty of Engineering
Mataram University
Email : nwahyus@yahoo.com

Mohan V. Aware
Electrical Engineering Department
Visvesvaraya National Institute of Technology
NAGPUR 440011 (INDIA)
Email: mva_win@yahoo.com

ABSTRACT

The dual-inverter fed open-end winding configuration can be categorized as a new breed of multi-level converters. The structure is simple and offers a lot of advantages. However, the development of suitable PWM schemes is more complicated, due to the availability of a large number of switching states and existence of the multiple two-dimensional planes. An overview that attempts to develop suitable modulation techniques for the dual-inverter fed five-phase machine drives recognizes that progress has been made over the past few years. This paper presents a performance comparison of three PWM schemes of the dual-inverter fed five-phase, open-end winding motor drives. The quality of the phase output voltages are compared and the adequate analyses are provided. The simulation results show that the Carrier Based Phase Disposition (PD) PWM scheme enables generation of the most excellent output voltage among the three PWM schemes. The Total Harmonics Distortion (THD) of the output voltages generated by the carrier based PWM scheme reduces by 65 % or 15 % on average compared to the THD of the output voltages produced by the URS PWM scheme and the decomposition PWM scheme respectively.

Keywords: Carrier based PWM; Dual-inverter fed; Open-end winding; Total Harmonics Distortion (THD)

1. INTRODUCTION

Adjustable speed ac drives require an inverter to produce voltage with variable frequency. In medium/high power applications, the limitation of rating power electronic devices used in the inverter is one of the main issues. The availability of the ratings of the power semiconductor devices are currently limited in terms of both current carrying and voltage blocking capability (and hence in terms of the total power as well). Increasing the number of levels of VSI is one way to solve the problem in the limitation of rating of power electronic devices. The other way is to increase the number of stator winding phases of the motor into higher than the traditional three-phase winding. Recently, the two techniques mentioned above are combined, which leads to realisation of a multi-phase multi-level inverter (Dordevic, et al., 2011; Gao, et al., 2010; López, et al., 2009). The multiple benefits are possible to achieve by combining the two technologies.

The structures of multi-level converters are mainly in form of the neutral point clamped (NPC), the flying capacitor (FC) and the cascaded converters (Lu, et al., 2010; McGrath, et al., 2007; Watkins, & Zhang, 2004). Among the cascaded converters, the dual-inverter fed open-end winding structure is relatively the newest one. The structure is simple and offers a

lot of advantages (Stemmler, and Guggenbach, 1993). The PWM schemes of dual-inverter fed three-phase motor drives have been the subject of research interest for decades. Numerous PWM methods have been developed and the technology has matured (Baiju, et al., 2004; Casadei, et al., 2007; Grandi, et al., 2006; Gupta, and Khambadkone, 2006). Yet, the PWM methods of the dual-inverter fed multi-phase machine are still very limited. The development of suitable PWM methods for the dual-inverter fed multi-phase drives is more complicated due to the availability of a large number of switching states and the existence of the multiple two-dimensional planes. Moreover, the available PWM schemes of the dual-inverter fed three-phase motor drives cannot be directly extended into multi-phase drives.

An overview that attempts to develop suitable modulation schemes for the dual-inverter fed multi-phase machine drives has been carried out over the past few years (Bodo, et al., 2011; Levi, et al., 2012; Jones, & Satiawan, 2012; Jones, et al., 2011; Satiawan, & Jones, 2011; Jones, et al., 2012; Patkar, et al., 2012; Bodo, et al., 2011). In the most PWM schemes, two modulators are utilised so that then they are individually modulated to reduce the complexity in the development of PWM schemes. A concise explanation, regarding the available PWM schemes for dual-inverter fed multi-phase motor drives, is presented in Section 2.3.

This paper presents the comparison and performance analysis of the available PWM schemes for the dual-inverter fed five-phase machine drives. Three PWM schemes, i.e URS PWM scheme, decomposition (DEC) PWM and Carrier Based (CB) PWM scheme are compared. The analysis mainly includes the performance quality of the phase load output voltage that is represented by the value of Total Harmonics Distortion (THD) and the low order harmonics content (the third and the seventh harmonics).

2. METHODOLOGY/ EXPERIMENTAL

2.1 Space Vector Voltages of Five-Phase VSI

In order to provide a better understanding into the Space Vector PWM (SVPWM) of the dual-inverter fed five-phase motor drives, it is beneficial to review the standard SVPWM technique of two-level five-phase VSI. A five-phase machine can be modeled in two 2D sub-spaces, so-called α - β and x - y sub-spaces (Dujic, et al., 2009). A machine with near sinusoidal magneto-motive force distribution and only current harmonic components which map into the α - β sub-space are able to develop useful torque and torque ripple, whereas those that map into the x - y sub-space do not contribute to the torque at all (Levi, 2008). A multi-phase machine with near-sinusoidal magneto-motive force distribution presents extremely low impedance to all non-flux/torque producing supply harmonics and it is therefore mandatory that the supply does not generate such harmonics. What this means is that the design of a five-phase PWM strategy must consider simultaneously both 2D sub-spaces, where the reference voltage, assuming pure sinusoidal references, is in the first plane, while reference in the other plane is zero.

Space-vector modulation technique of a five-phase voltage source inverter (VSI) is more complex than for the three-phase VSI due to the larger number of space vectors and the existence of the additional sub-space where the vectors map. The five-phase VSI produces 32 voltage space vectors and they are distributed in a five-dimensional space. The five-dimensional space is decomposed into two two-dimensional sub-spaces (α - β and x - y

planes) and one single-dimensional sub-space (zero-sequence). If the load is assumed as a star-connected with isolated neutral point, then zero-sequence components will not exist. As a result only two two-dimensional sub-spaces (α - β and x - y) need to be considered in order to yield a satisfactory performance.

Voltage space vectors of two level five-phase VSI for both α - β and x - y planes are shown in Fig. 1. The voltage space vectors are labeled with decimal numbers, which, when converted into a binary sequence ? revealing the values of the switching functions of each of the inverter legs. Active (non-zero) space vectors belong to three groups in accordance with their magnitudes - small, medium and large space vector groups. Four active space vectors are required to generate sinusoidal voltages (Dujic, et al., 2009; Levi, et al., 2007). Two neighboring large and two medium space vectors are selected in order to provide zero average voltage in the x - y plane.

2.2 Five-Phase Open-End Winding Topology

The structure of dual-inverter fed open-end winding motor drives is realised by opening the neutral point of the machine and supplying the machine from both sides of stator windings by two VSIs. By using this structure, the inverter can be operated as a two-level, three-level or four-level inverter, depending on the ratio of DC-link voltages, without the need to change the structure of the inverter.

Fig. 2 illustrates the open-end winding structure, based on utilization of two, two-level five-phase VSIs. The two inverters are identified with the indices 1 and 2. Inverter legs are denoted with capital letters, A, B, C, D, E and the negative rails of the two dc links are identified as $N1$ and $N2$. Machine phases are labeled as a, b, c, d, e . Phase voltage positive direction is with reference to the left inverter (inverter 1). Two isolated DC supplies are assumed so that the common mode voltage (CMV) v_{N1N2} is of non-zero value (the issue of CMV elimination is not addressed here). The resulting space vectors in dual-inverter supply mode will depend on the ratio of the two DC bus voltages. The situation considered further on is the setting $v_{dc1} = v_{dc2} = v_{dc} / 2$, which gives the equivalent of single-sided three-level supply. Using the notation of Fig. 2, phase voltages of the stator winding can be given as (Levi, et al., 2010):

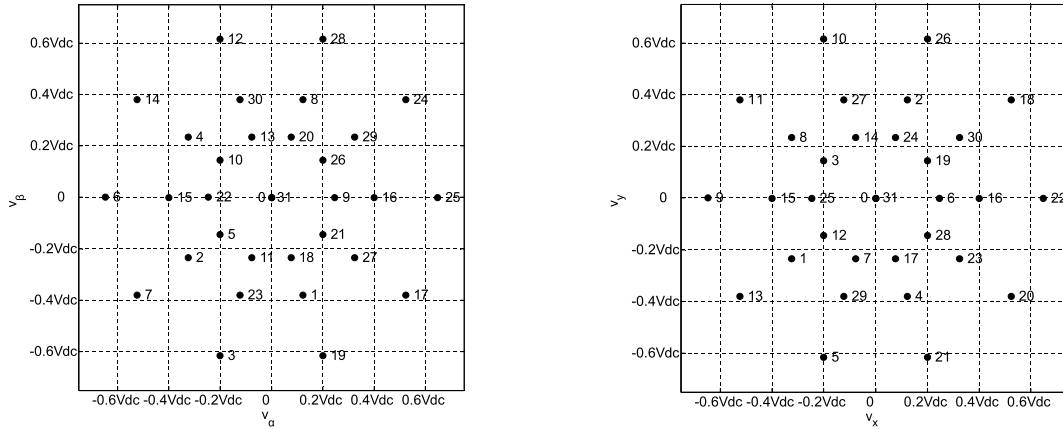

Figure 1 Two-level five-phase VSI space vectors in the $\alpha\text{-}\beta$ and $x\text{-}y$ planes.

$$\begin{aligned}
 v_{as} &= v_{A1N1} + v_{N1N2} - v_{A2N2} \\
 v_{bs} &= v_{B1N1} + v_{N1N2} - v_{B2N2} \\
 v_{cs} &= v_{C1N1} + v_{N1N2} - v_{C2N2} \\
 v_{ds} &= v_{D1N1} + v_{N1N2} - v_{D2N2} \\
 v_{es} &= v_{E1N1} + v_{N1N2} - v_{E2N2}
 \end{aligned} \tag{1}$$

Space vectors of phase voltages in the two planes are determined with;

$$\begin{aligned}
 \bar{v}_{\alpha\text{-}\beta} &= (2/5)(v_a + \underline{a}v_b + \underline{a}^2v_c + \underline{a}^3v_d + \underline{a}^4v_e) \\
 \bar{v}_{x\text{-}y} &= (2/5)(v_a + \underline{a}^2v_b + \underline{a}^4v_c + \underline{a}^6v_d + \underline{a}^8v_e)
 \end{aligned} \tag{2}$$

where $\underline{a} = \exp(j2\pi/5)$. Using (1) and (2), one gets ;

$$\begin{aligned}
 \bar{v}_{\alpha\text{-}\beta} &= \bar{v}_{\alpha\text{-}\beta(A1B1C1D1E1)} - \bar{v}_{\alpha\text{-}\beta(A2B2C2D2E2)} \\
 \bar{v}_{x\text{-}y} &= \bar{v}_{x\text{-}y(A1B1C1D1E1)} - \bar{v}_{x\text{-}y(A2B2C2D2E2)}
 \end{aligned} \tag{3}$$

since $v_{N1N2}(1 + \underline{a} + \underline{a}^2 + \underline{a}^3 + \underline{a}^4) = 0$. In (3) the two space vectors on the right-hand sides of the two equations are corresponding voltage space vectors of the two five-phase two-level VSIs. Voltage space vectors, produced by the 1,024 possible switching states are illustrated in Fig. 3 for the $\alpha\text{-}\beta$ and $x\text{-}y$ planes. There are 211 voltage space vectors and 21 active phase voltage space vectors per each 36 degrees sector. Voltage space vector mapping into the $x\text{-}y$ plane follows the pattern that exists for a five-phase VSI, thus converting the largest vectors of the first plane map into the smallest vectors of the second plane, and vice versa (Levi, et al., 2010).

As the 1024 switching states are mapped in 211 vector locations, the switching states redundancy is considerably high in this inverter structure. This will give rise to further complexity in selecting the proper switching states for the developed PWM schemes.

2.3 Review of PWM Schemes for the Dual- Inverter Fed Five-Phase Motor Drives

The initial PWM schemes of the dual-inverter fed five-phase open-end winding motor drives are carried out by simply apportioning the voltage reference unequally between two inverters. The division of the voltage reference is governed by the value of modulation index. This PWM scheme is then named as Unequal Reference Sharing (URS). For clarity, the modulation index is defined as $M = v^{**} / (0.5V_{dc})$. Where v^{**} is the modulating reference voltage and v_{dc} is the value of DC-link voltage of individual inverter. In the higher modulation index ($0.525 < M \leq 1.05$), two standard five-phase space vector modulators (SVM) are utilised, one for each inverter. In the lower modulation index ($M \leq 0.525$) only one inverter is modulated, while the other inverter is switched off (clamped at zero vector). The PWM scheme enables multi-level operation in the higher modulation index and results in improved phase output voltage for all speed ranges compared to two-level PWM (Levi, et al., 2012; Jones, & Satiawan, 2012).

Subsequently, a SVPWM scheme for dual-inverter fed five-phase drives based on the decomposition method is developed in (Jones, et al., 2011). The three-level voltage vectors in the decagon are decomposed into a number of two-level decagons. The PWM scheme operates the inverters in different mode of operation. In the higher modulation index, one inverter operates in square wave mode and the other inverter operates in PWM mode. In the lower speed range, only one inverter operates in PWM mode. A different approach of SVPWM that is applied in the decomposition PWM method is presented in (Satiawan, & Jones, 2011). The SVPWM is realised using the Unified PWM technique, as introduced in (Kim, and Sul, 1996) for three-phase drives. The PWM modulator is required to generate outputs with multiple frequencies. The output voltage that contains several low-order harmonics than that used to eliminate the low-order harmonics is produced by the square wave mode inverter. As a result nearly sinusoidal output voltages are able to be produced.

The decomposition PWM scheme works well for higher speed ranges, but in particular the speed range that equals to the modulation index of $0.525 < M \leq 0.637$, which marks condition when a significant increase in one of DC-link voltages has occurred. In this range the power supplies by the square wave inverter is higher than the power required by the load. As a consequence, the PWM inverter supplies a negative power to the load that causes a power being transferred from inverter 1 to inverter 2. The problem of the rise one of the DC-link voltage is solved by reducing the DC- link voltage of the square wave mode inverter so that the power delivered by the square wave inverter will never be higher than the power required by the load (Jones, et al., 2012).

Furthermore, carrier based (CB) PWM methods for a dual-inverter fed five-phase drive is presented in (Bodo, et al., 2011). According to the shape of the carrier signals, a (various?) carrier based PWM, i.e Phase Disposition (PD) PWM, Alternative Phase Opposition Disposition (APOD) PWM and Phase Shifted (PS) PWM, was studied. The result shows that carrier based PD PWM is the most suitable scheme for the dual-inverter fed structure. It is therefore, the only carrier based PD PWM scheme examined in this paper.

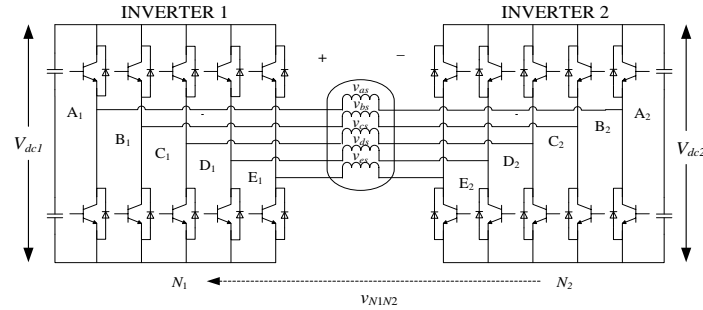

Figure 2 The structure of a five-phase dual two-level inverter fed open-end winding drive.

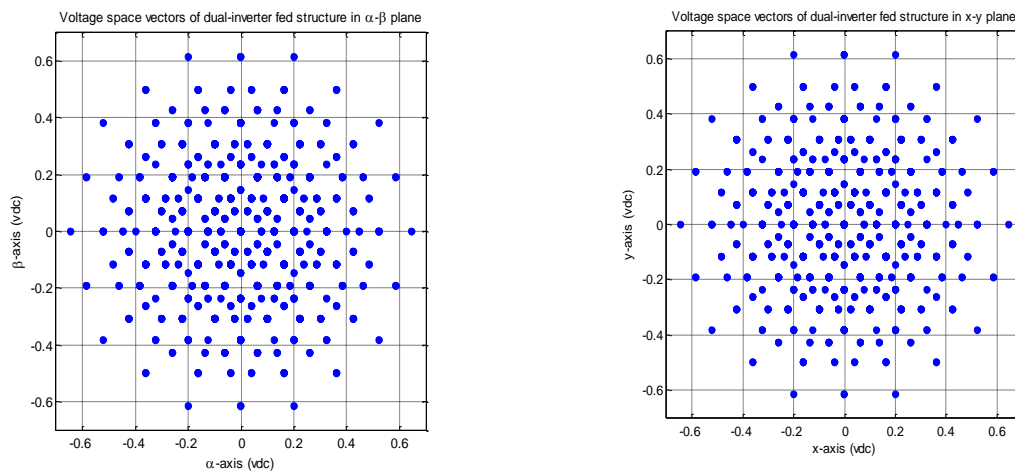

Figure 3 Space vector distribution of the dual-inverter supplied five-phase open-end topology in the α - β and x-y planes for equal DC-link voltage.

3. RESULTS

In order to evaluate the performance of the PWM schemes, a series of **detailed** simulation was done using Matlab/Simulink. The inverters are modeled by using SimPowerSystem Blokset and the gating signals are generated using Simulink. A set of five-phase static load is attached into the respective phase of the output terminals of inverter 1 and inverter 2. The DC-link voltage of each inverter is 300 V, (except at the decomposition PWM scheme the ratio of DC link voltage is 271.38 : 328.62 V), the switching frequency of the PWM modulators is 2 kHz and the effect of dead time is not included in the simulation. At the rating frequency of 50 Hz, the modulation index, $M = 1$.

Figs. 4 (a - c) show the phase "a" load voltage, the phase "a" leg voltages of inverter 1 and inverter 2 and the respective harmonics spectra of three PWM schemes for a particular modulation index, $M = 0.8$. It can be seen that the nearly sinusoidal output voltages are able to **be achieved** by the three PWM schemes. The harmonics spectra contain only the fundamental **components** while the low order harmonics are shifted into **multiples** around **the** switching frequency and its side band.

Furthermore, the phase leg voltages of the two inverters are shown in the middle and lower traces of Fig. 4. The leg voltages confirm that the URS PWM scheme operates both inverters in PWM mode (Fig. 4 (d) and Fig 4 (g)). The spectra of the leg voltages indicate that the leg voltages dominantly contain the fundamental components, the fifth harmonics and harmonics around switching frequency. As expected, the Leg voltage of inverter 1 provides a higher fundamental component than the inverter 2 since at $M = 0.8$ inverter 1 operates in its maximum operating region, while inverter 2 operates in the lower operating region. The mutual relationship of both inverters results in a free low-order harmonics output voltage.

Meanwhile in the decomposition PWM scheme, the spectra of the leg voltages indicate that inverter 1 operates in square wave mode and the inverter 2 operates in PWM mode (Fig. 4 (e) and Fig. 4 (h)). The low-order harmonics produced by the square wave inverter are compensated for by the harmonics generated by the PWM inverter. As a result, the load phase voltages contain free low order harmonics. Furthermore, the leg voltages of the carrier based (CB) PWM scheme (Fig. 4 f) and Fig 4 (i)) indicate that the two inverters operate alternately between the square wave mode and PWM mode for every one cycle of operation. The harmonics spectra of the leg voltages of the CB PWM show that the fundamental component and the low order harmonics content that is generated by inverter 1 are the same as those generated by inverter 2. As a result, a better control of the low order harmonics content is provided and hence superior output voltages quality is able to be achieved. Surprisingly, the substantially zero component and some even harmonics components appeared in the inverter leg voltages besides those of the fifth harmonic. The even harmonics are present in the leg voltages of the CB PWM scheme due to the asymmetrical waveforms of the leg voltages in one cycle of operation. The zero component and the even harmonics do not affect the performance of the load phase voltage. Nevertheless, they may contribute in the value of the common mode voltage (CMV). In addition, the same harmonics content in the leg voltages indicates a balanced operation between two inverters that ensures the power balancing capability of the PWM scheme to avoid the rise of the DC-link voltage.

4. DISCUSSION

4.1 Total Harmonics Distortion (THD)

To further examine the performance of the PWM schemes, the simulation was repeated from $M = 0.05$ to $M = 1.05$ with 0.005 steps of incremental order. The THD and the value of the low order harmonics (the third and the seventh harmonics) are noted and then compared. The number of harmonics included in the calculation is up to 100.000 Hz. In order to aid the clarity, only the THD in the range of $0.02 \leq M \leq 1.05$ are shown in Fig. 5. It is revealed that in the higher modulation index ($M > 0.525$) the THD of the CB PWM scheme is significantly better than the URS PWM scheme. In the lower modulation index ($M \leq 0.525$), the performance of the URS PWM and CB PWM is the same, since both systems operate in the same manner (only one inverter operates). The CB PWM also presents a better output voltage quality than the decomposition PWM scheme. The better performance is achieved due to the different DC-link ratio applied in the decomposition scheme, while the CB PWM is applied to the equal DC-link voltage. The THD of the output voltages generated by the CB PWM scheme are reduced significantly by 65 % and

15 % on average compared to the THD of the output voltages generated by the URS PWM scheme and the decomposition of the PWM scheme, respectively.

4.2 Low Order Harmonics Content

The performance of the PWM schemes is also validated by comparing the content of the third and the seventh harmonics as shown in Fig. 6. It can be seen that in general, the output voltages generated by the CB PWM scheme contain the smaller low order harmonics for most modulation indices than for the two PWM schemes. The result is in good accordance with the value of the THD. The results presented above denote that the performance of the CB PWM is superior between the two PWM schemes. The simplicity of the development procedure of the CB PWM scheme is another worthy value, besides the ability in keeping a balanced operation between the two inverters for a better power sharing capability.

5. CONCLUSION

This paper compares the three PWM schemes for dual inverter fed five-phase open-end winding motor drives. The PWM schemes were verified via simulation and an adequate analysis is provided. The side by side comparison indicates that the CB PWM scheme is able to synthesize the most excellent output voltage among the three PWM schemes. The superiority of the CB PWM scheme is confirmed by the value of THD and the content of low order harmonics. The simplicity and the inherent power balancing capability is another merit of the Carrier Based PD PWM scheme. In the future, the performance analysis of the PWM schemes from the perspective of current / torque ripple and common mode voltage is also beneficial to study to further show the features of the developed PWM schemes.

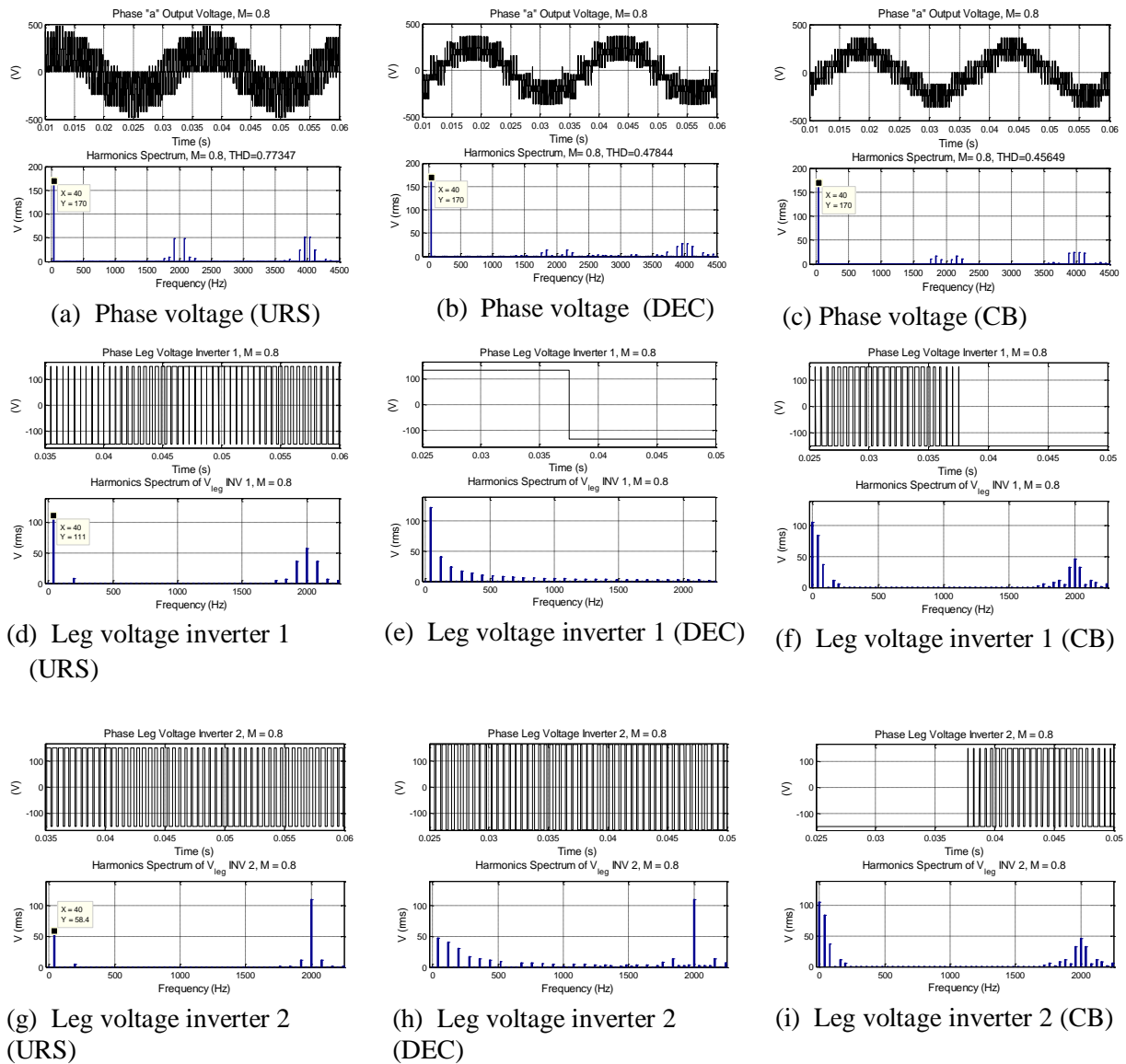

Figure 4 Phase “a” load output voltage and phase “a” leg voltage of inverter 1 and inverter 2 of the three PWM schemes at particular modulation index, $M = 0.8$

7. REFERENCES

- Baiju, M.R., Mohapatra, K.K., Kanchan, R.S., Gopakumar, K., (2004), A dual two-level inverter scheme with common mode voltage elimination for an induction motor drive, IEEE Transactions on Power Electronics, Vol. 19, No. 3, pp. 794-805.
- Bodo, N., Levi, E., and Jones, M., (2011), Carrier-based modulation techniques for five-phase open-end winding drive topology, in Proc. IEEE Industrial Electronics Annual Conference IECON, Melbourne, Australia, pp. 3529-3534.

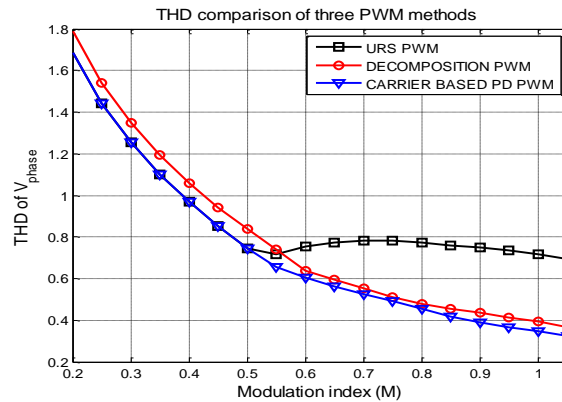
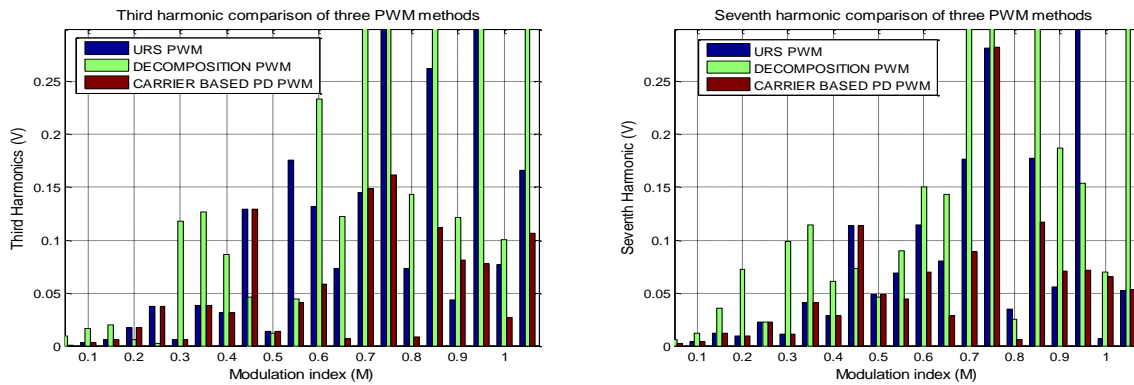

Figure 5 THD comparison of PWM schemes of the dual-inverter fed five phase drives.



(a) Third harmonics

(b) Seventh harmonics

Figure 6 Harmonics comparison of PWM schemes of dual-inverter fed five phase drives.

- Casadei, D., Grandi, G., Lega, A., Rossi, C., Zarri, L., (2007), Switching technique for dual-two level inverter supplied by two separate sources, Proc. IEEE Applied Power Electronics Conf. APEC, Anaheim, California, USA, pp. 1522-1528.
- Dordevic, O., Jones, M., and Levi, E., (2011), A space-vector PWM algorithm for a three-level seven-phase voltage source inverter, in Proc. Eur. Power Elec. and Appl. Conf. EPE, Birmingham, UK, CD-ROM No. 0123.
- Dujic, D., Jones, M., Levi, E., (2009), Generalized space vector PWM for sinusoidal output voltage generation with multi-phase voltage source inverters, Int. Journal Industrial Electronics and Drives, Vol. 1, No. 1, pp. 1-13.
- Gao, L., and Fletcher, J. E., (2010), A space vector switching strategy for three-level five-phase inverter drives, IEEE Trans. on Ind. Elec., Vol. 57, No. 7, pp. 2332-2343.
- Grandi, G., Rossi, C., Lega, A., and Casadei, D., (2006), Multilevel operation of a dual two-level inverter with power balancing capability, in Proc. IEEE Industry Applications Society Annual Meeting IAS, Tampa, FL, USA, pp. 603-610.
- Gupta, K., and Khambadkone, A. M., (2006), A space vector PWM scheme for multilevel inverters based on two-level space vector PWM, IEEE Trans. on Ind. Elec., Vol. 53, pp. 1631-1639.

- Jones, M., Satiawan, I. N., and Levi, E., (2011), A three-level five-phase space-vector modulation algorithm based on the decomposition method, in Proc. IEEE Int. Elec. Machines and Drives Conf. IEMDC, Niagara Falls, Canada, pp. 1219-1224.
- Jones, M., Satiawan, I.N., Bodo, N., Levi, E., (2012), A dual five-phase space-vector modulation algorithm based on the decomposition method, IEEE Transactions on Industry Applications, Vol. 48, No. 6, pp. 1 -11.
- Jones, M., Satiawan, I.N., (2012), A simple multi-level space vector modulation algorithm for five-phase open-end winding drives, Transactions on International Association for Mathematics and Computers in Simulation (IMACS) journal, Vol. 90, pp. 74-85.
- Kim, J.S., and Sul, S.K., (1996), A novel voltage modulation technique of the space vector PWM, IEEE Transactions on Industry Applications, Vol. 116, No. 8, pp. 820-825.
- Levi, E., Bojoi, R., Profumo, F., Toliyat, H., Williamson, S., (2007), Multi-phase induction motor drives: A technology status review, IET Elect. Power Apps 1(4) pp.489-516.
- Levi, E., (2008), Multi-phase electric machines for variable-speed applications, IEEE Transactions on Industrial Electronics 55 (5), pp. 1893-1909.
- Levi, E., Jones, M., and Satiawan, W., (2010), A multi-phase dual-inverter supplied drive structure for electric and hybrid electric vehicles, in Proc. IEEE Vehicle Power and Propulsion Conf. VPPC, Lille, France, CD-ROM paper 95-45630.
- Levi, E., Satiawan, I.N.W., Bodo, N., Jones, M., (2012), A space-vector modulation scheme for multilevel open-end windings five-phase drives, IEEE Transactions on Energy Conversion, Vol. 27, No. 1, pp. 1-10.
- López, O., Alvarez, J., Doval-Gandoy, J., and Freijedo, F. D., (2009), Multilevel multiphase space vector PWM algorithm with switching state redundancy, IEEE Trans. on Ind. Elec., Vol. 56, No. 3, pp. 792-804.
- Lu, S., Mariethoz, S., Corzine, K. A., (2010), Asymmetrical cascade multi-level converters with noninteger or dynamically changing DC voltage ratios: Concepts and modulation techniques, IEEE Trans. on Industry Applications 57 (7), pp. 1815-1824.
- McGrath, B.P., Meynard, T.A., Gateau, G., Holmes, D.G.,(2007), Optimal Modulation of Flying Capacitor and Stacked Multicell Converters Using a State Machine Decoder, IEEE Transactions on Power Electronics Vol. 22, No. 2, pp. 508-516.
- Satiawan, W., Jones, M., (2011), A multi-frequency PWM scheme for multi-level five-phase open-end winding drives,” Proc. Universities’ Power Engineering Conference UPEC, Soest, Germany, pp. 1- 6.
- Stemmler, H., and Guggenbach, P., (1993), Configurations of high-power voltage source inverter drives, in Proc. Eur. Power Elec. and Appl. Conf. EPE, Brighton, UK, Vol. 5, pp. 7-14.
- Watkins, S.J., Zhang, L., (2004), Multilevel space vector PWM control schema for a flying-capacitor inverter, Proc. IEEE Power Electronic, Machines and Drives PEMD, Edinburgh, UK, Vol. 1, pp.12-17.